

TTC6 FACTORY Team

#30106 RC10T6 Factory Team Kit

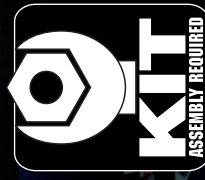

1:10 Scale Electric 4WD Touring Car Kit Manual & Catalog 8/11

TEAM ASSOCIATED



Designed in California, USA

:: Introduction

Thank you for purchasing this Team Associated product. This assembly manual contains instructions and tips for building and maintaining your new RC10TC6. Please take a moment to read through this manual to help familiarize yourself with these steps.

We are continually changing and improving our designs; therefore, actual parts may appear slightly different than in the illustrations. New parts will be noted on supplementary sheets located in the appropriate parts bags. Check each bag for these sheets before you start to build.

:: KIT Features

Team Associated Factory Team TC6 is Area-51's next generation touring car. Based off decades of race experience with its roots heavily planted from the bar setting TC3, the TC6 blends the best of performance and adjustability to compete in today's touring car racing class. The updated chassis platform considers many hours of testing from Factory Team drivers over the last few race seasons, keeping focus strictly on brushless motors and LiPo batteries. The resulting layout is optimized for the speeds and grip levels that are now higher than ever before... the RC10TC6-FT is definitely another Champion by Design from Team Associated!

- Chassis layout optimized for Lithium Batteries and Brushless Motors
 - Motor moved toward chassis center by 13mm from TC5
 - Ultra narrow LiPo chassis with two battery positions, forward and back
 - Servo mounting slots to ensure proper fit of any servo
 - Spur gear lowered by 5mm from TC5
 - Lengthened top plate with symmetric mounting points for equal flex
 - Motor mounts to centralized point in chassis for equal flex
- Common bulkhead layout minimizes spare part cost
- Updated steering system
 - More Ackermann options (16 positions total) to fine tune steering feel
 - Improved steering input rate for more consistent handling
- VCS3 Shock with hard anodized threaded shock bodies
 - Bottom loading seal system for ease of build
 - TiN coated shock shaft
 - Piston attaches to shock shaft with screw for tight clamping and no slop
 - Improved bladder for more consistent build through time
 - Threaded collar with fine pitch thread for ease of accurate ride height adjustment
 - Increased stroke for more up-travel at wheel
- Long upper link option for increased corner speed
- Hard anodized diff outdrives for low wear and long life
- Cross-compatibility with TC5 suspension components

:: Additional Features

Your new TC6 comes unassembled and requires the following items for completion. (refer to catalog section for suggestions):

- 1:10th scale electric motor and electronic speed control
- 3.7V-7.4V LiPo, 6.0V LiFe, or 4.8V-7.2V NiMh
- Battery charger (suited for, and particular to, one of the batteries mentioned above)
- 2 channel surface transmitter, 2 channel receiver, and steering servo
- 1:10th scale lexan touring car body
- Lexan specific spray paint for body
- 1:10th scale rubber (or foam) touring car tires

:: Other Helpful Items

- Silicone Shock Fluid (Refer to catalog for complete listings)
- Body Scissors (AE Part # 1737)
- FT Hex Wrenches (AE Part # 1541)
- Needle Nose Pliers
- Soldering Iron
- Calipers or a Precision Ruler
- Reamer / Hole Punch
- Hobby Knife
- Wire Cutters
- Multi Tool (AE Part #7494)

Associated Electrics, Inc.
 26021 Commercentre Dr.
 Lake Forest, CA 92630



Customer Service
 Tel: 949.544.7500
 Fax: 949.544.7501

:: Table of Contents

1.....Cover	14.....Top Plate / Bearing Caps Install (Bag G-GG)
2.....Introduction	15-16.....Steering Block Build / Install (Bag H)
3.....Table of Contents	17.....Rear Hubs Build / Install (Bag H)
4-5.....Shock Build (Bag A-AA)	18.....Shocks Install (Bag I)
5-6.....Front Slipper Spool Build (Bag B-BB)	18.....Bumper Build / Install (Bag I)
6-8.....Rear Differential Build (Bag B-BB)	19.....Pivoting Body Mounts Install (Bag I)
8.....CVA Axle Build (Bag C)	19.....Battery Braces / Antenna Mount Install (Bag I)
9.....Turnbuckle Build (Bag D)	20.....Anti-Roll Bars Build / Install (Bag J)
9.....Front Bulkhead Build (Bag E-EE)	21.....Servo Build / Install (Bag K)
10.....Rear Bulkhead Build (Bag E-EE)	21-22.....Electronics Install (Bag L)
10.....Spur Gear Bulkhead / Motor Mount Install (Bag E-EE)	22.....Wheels / Tires Build / Install (Bag L)
11.....Shock Tower Build (Bag E-EE)	23-25.....Tuning Tips
11-12.....Steering Bellcrank Build / Install (Bag F)	26-33.....Catalog
12.....Spur Gear Shaft Build (Bag G-GG)	34.....Notes
13.....Spur Gear Hub / Belt Install (Bag G-GG)	35.....Setup Sheet "Kit Setup"
13-14.....Front Slipper Spool Install (Bag G-GG)	36.....1:1 Hardware "Fold Out"
14.....Rear Differential Install (Bag G-GG)	37.....Setup Sheet "Blank"
	38.....Back Cover

:: Notes

This symbol indicates a special note or instruction in the manual.



There is a 1:1 hardware foldout page in the back of the manual. To check the size of a part, line up your hardware with the correct drawing until you find the exact size. Each part in the foldout has a number assigned to it for ordering replacement parts.

Associated Electrics, Inc.
26021 Commercentre Dr.
Lake Forest, CA 92630



Customer Service
Tel: 949.544.7500
Fax: 949.544.7501

<http://www.TeamAssociated.com> • <http://www.RC10.com> • http://twitter.com/Team_Associated • <http://bit.ly/AEonFacebook>

:: Shock Build - Bag A-AA - Step 1

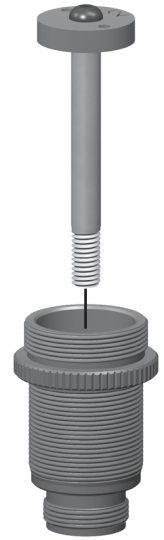
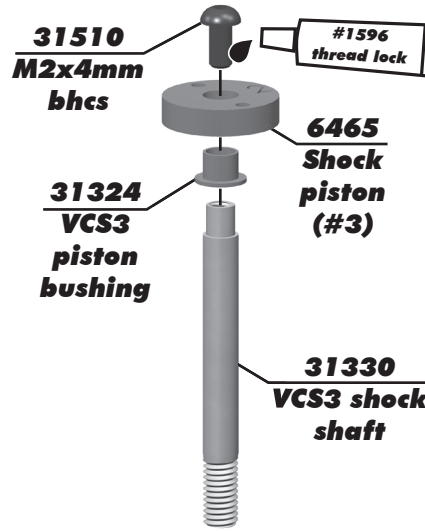

:: Shock Build - Bag A-AA - Step 2

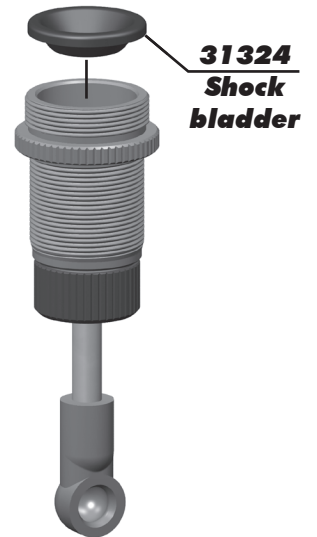
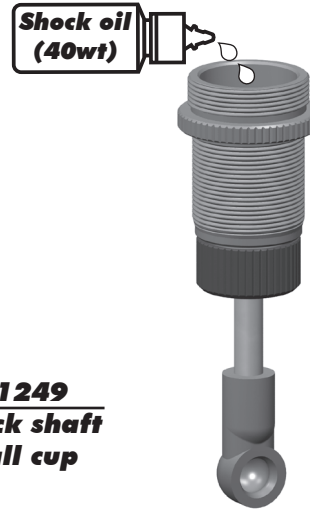
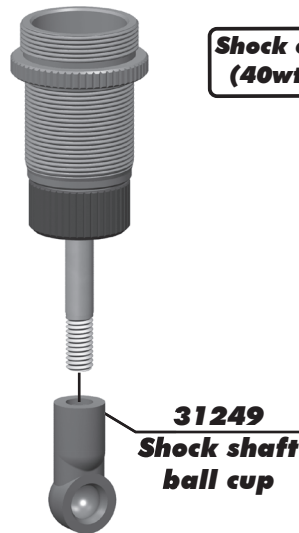
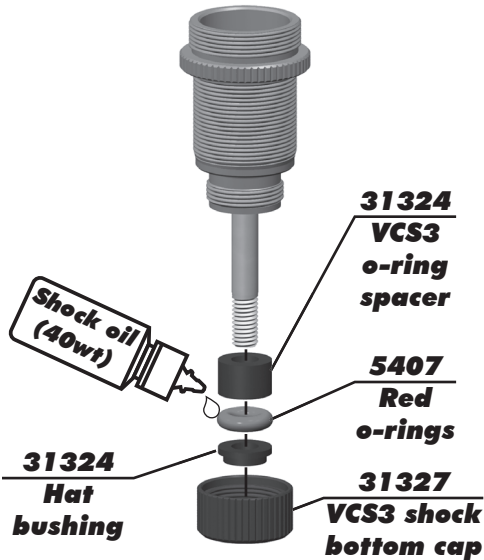

:: Shock Build - Bag A-AA - Step - 3

Bladder Installation

With the shaft fully extended, place bladder on the top of the shock body, displacing the extra oil. While maintaining pressure on the bladder against the shock body, carefully lift one side of the bladder to allow any extra oil to escape. Place stock cap on top of bladder, and secure it by threading the aluminum cap retainer onto the shock body.

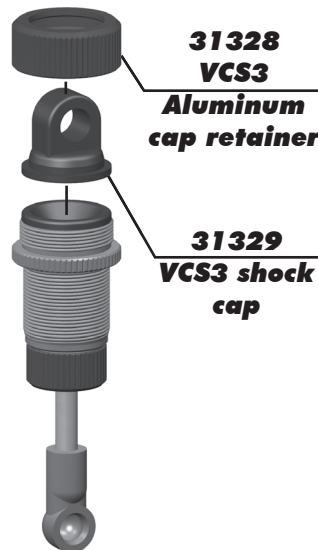

:: Shock Build - Bag A-AA - Step 4

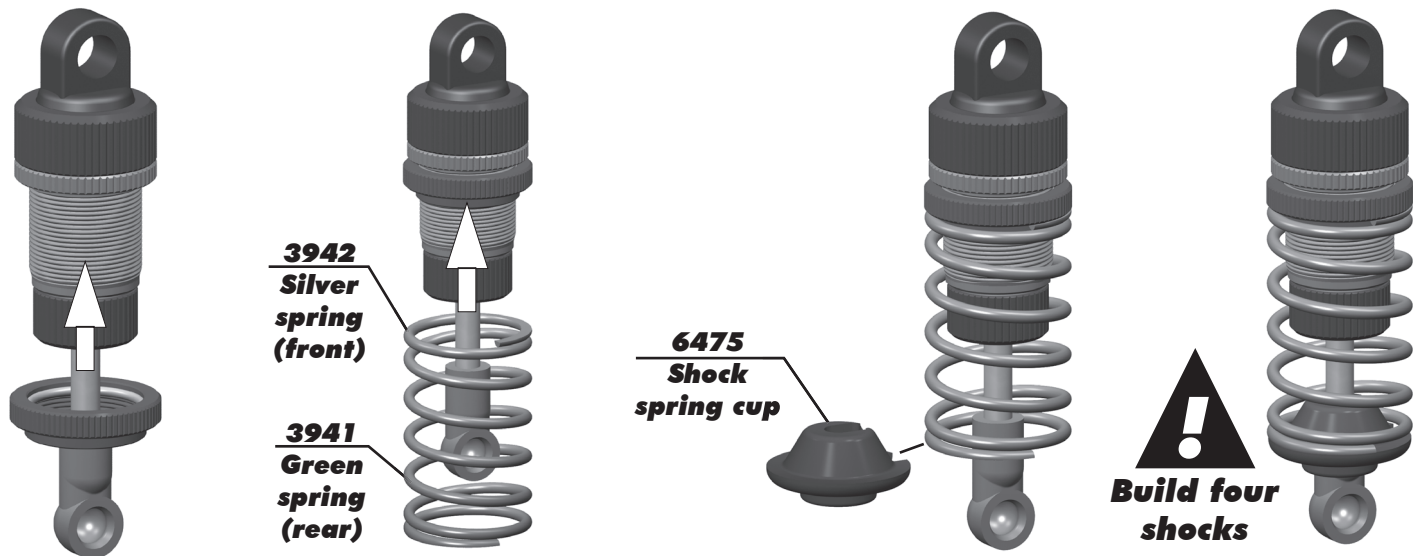

:: Front Slipper Spool Build - Bag B-BB - Step 1

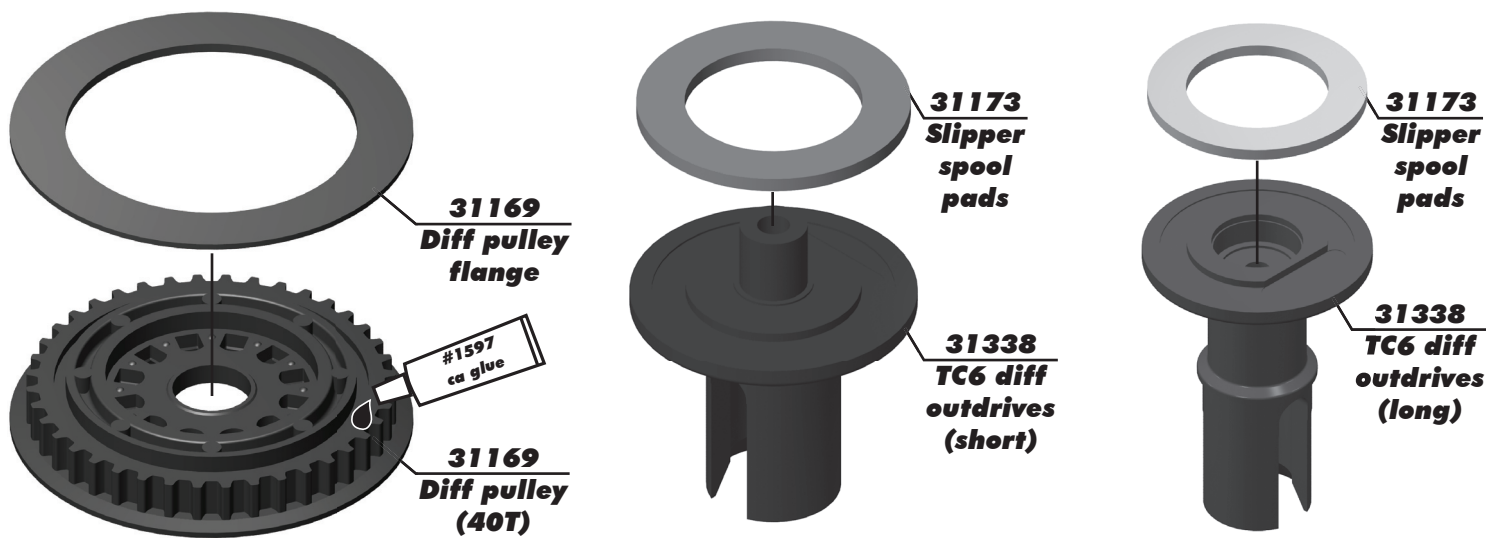

:: Front Slipper Spool Build - Bag B-BB - Step 2

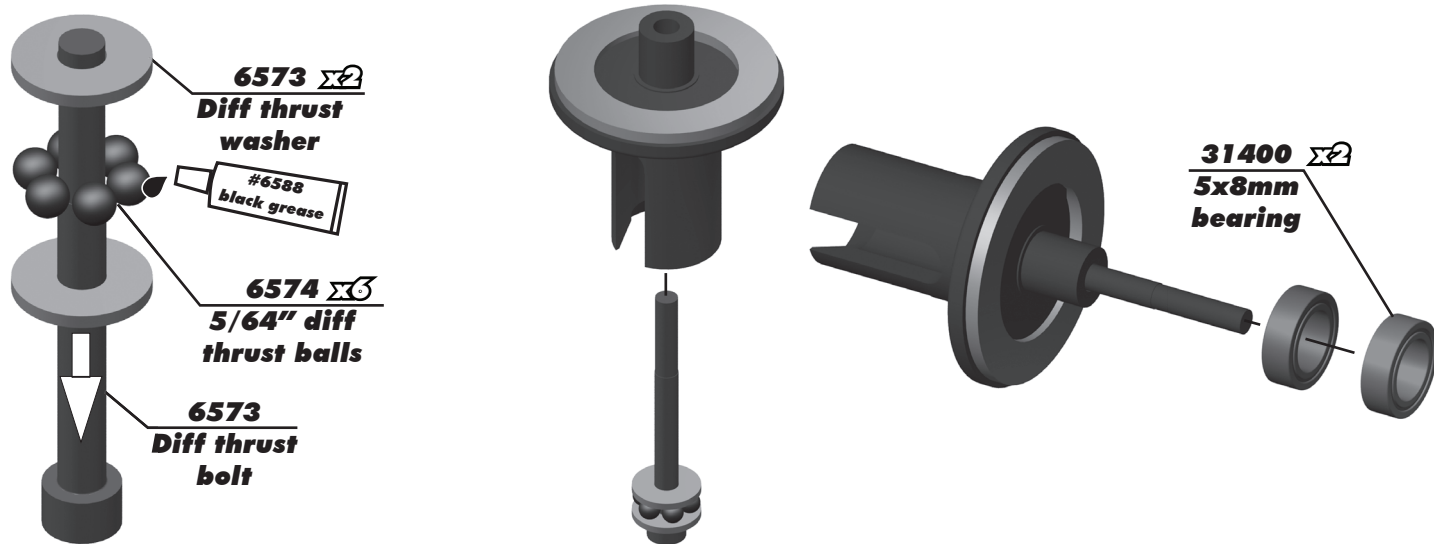

:: Front Slipper Spool Build - Bag B-BB - Step 3

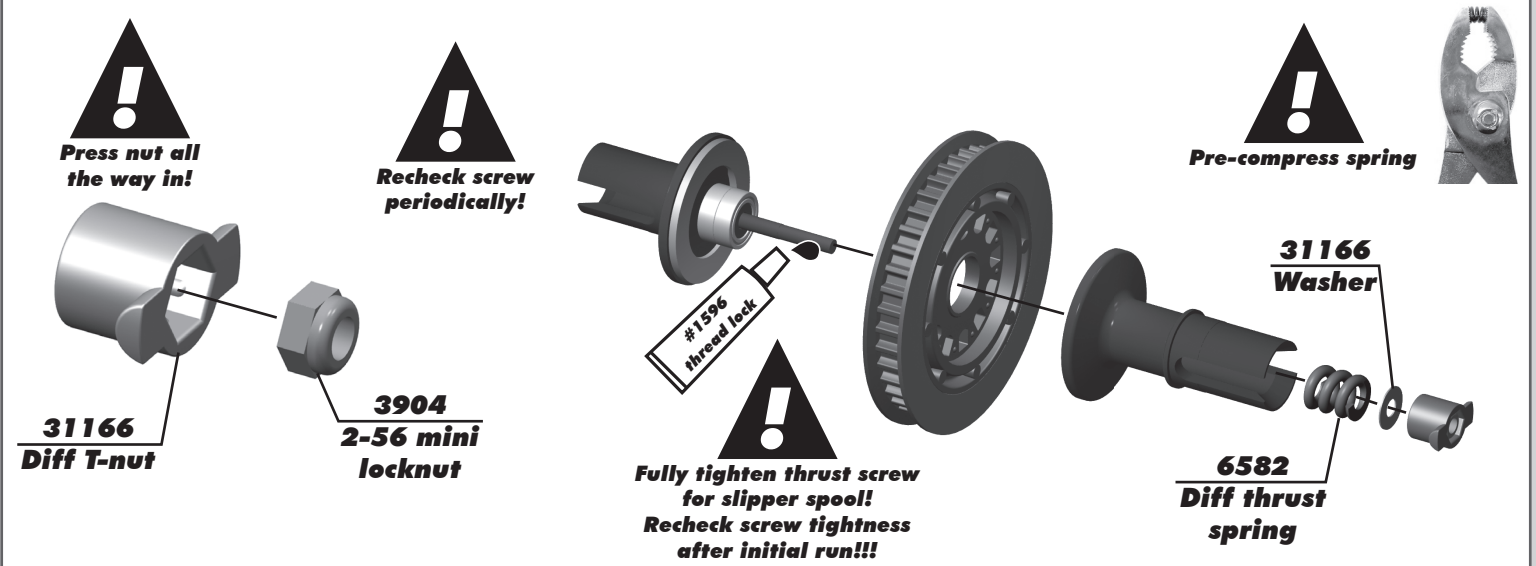

:: Front Slipper Spool Build - Bag B-BB - Step 4

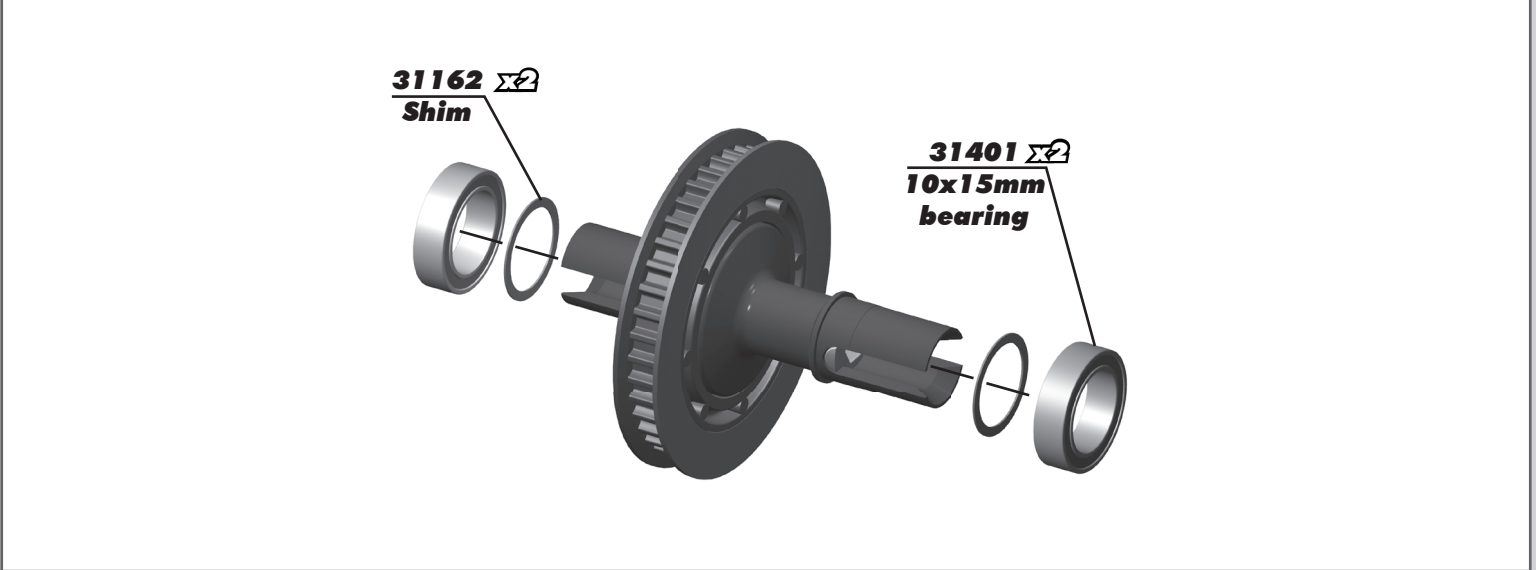

:: Rear Differential Build - Bag B-BB - Step 1

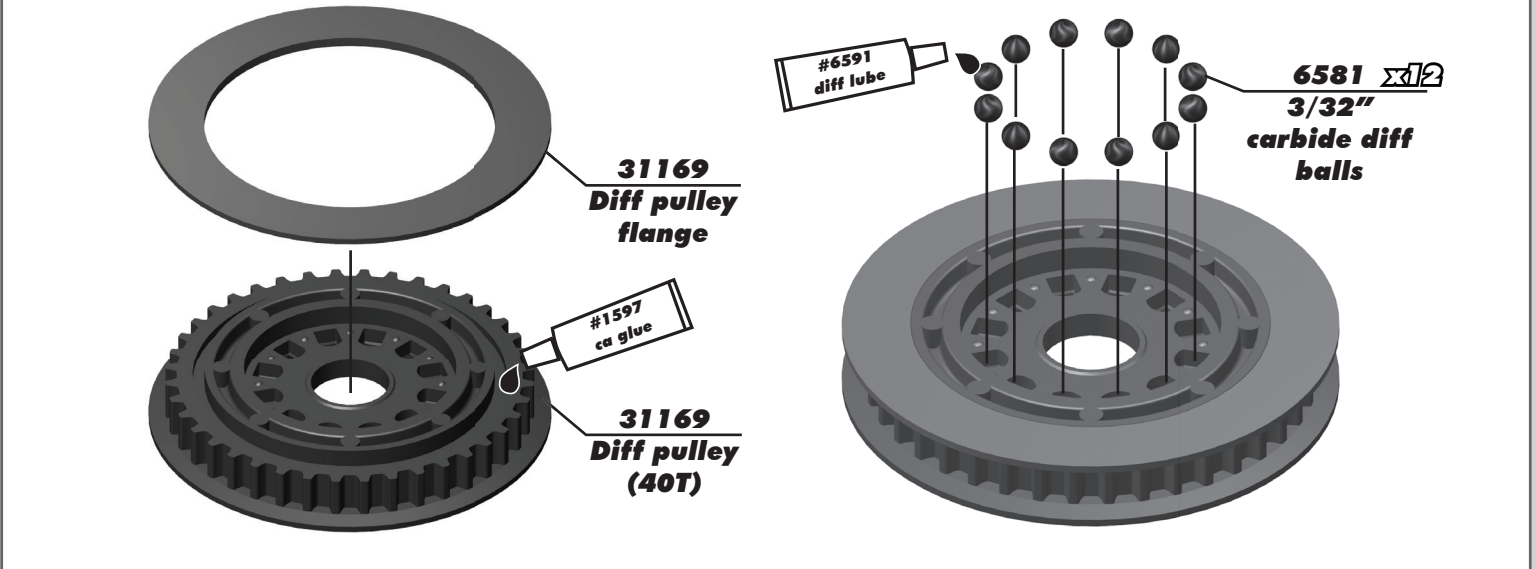

:: Rear Differential Build - Bag B-BB - Step 2

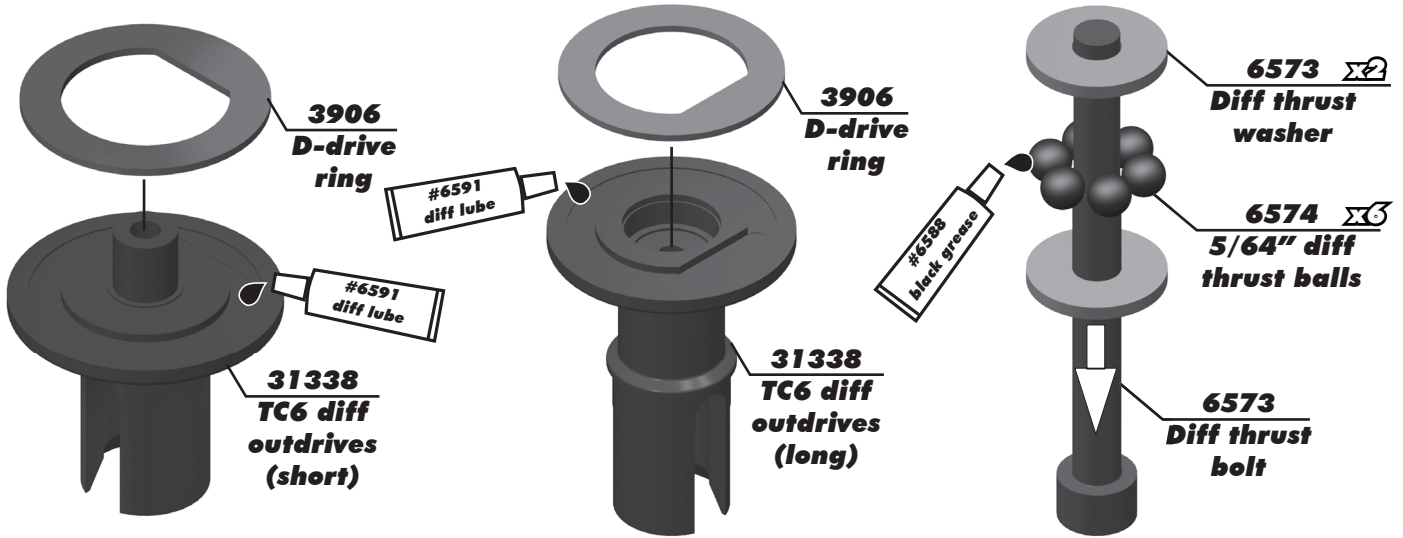

:: Rear Differential Build - Bag B-BB - Step 3

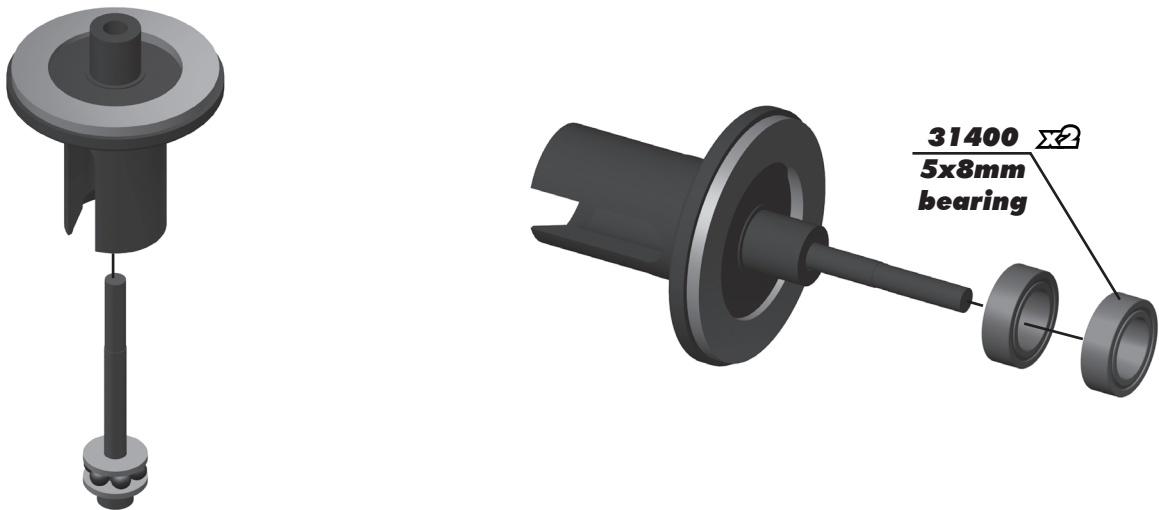

:: Rear Differential Build - Bag B-BB - Step 4

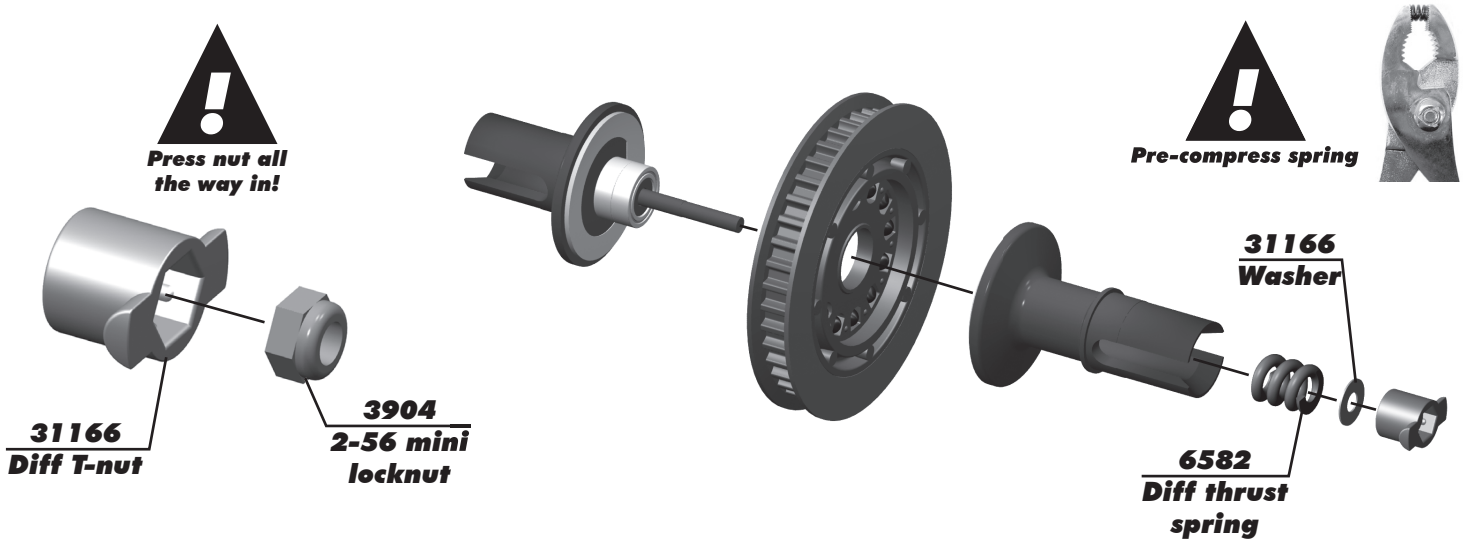

:: Rear Differential Build - Bag B-BB - Step 5

Kit Setting
 0
 -1/8
 -1/4
 -3/8
 -3/4
 -5/8
 -1/4

5/64" hex wrench installed in diff bolt

31162 Shim

31401 10x15mm bearing

Diff Setting:
 Tighten thrust screw until spring is fully compressed. Then loosen 1/8 turn (see diagram). Re-check after initial run.

:: CVA Axle Build - Bag C - Step 1

31232 CVA bones

#658 black grease

31227 CVA coupler

31227 CVA cross pin

31231 CVA axle

31237 retaining clip

:: CVA Axle Build - Bag C - Step 2

Note!
 Align the gap in the pin retainer to be opposite of the CVA pin.

31238 CVA blade

Note!
 Build four CVA's

:: Turnbuckle Build - Bag D - Step 1

Servo Turnbuckle

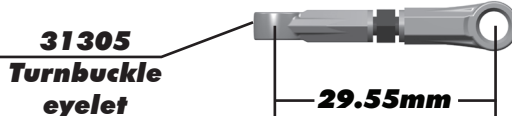

Camber Turnbuckle

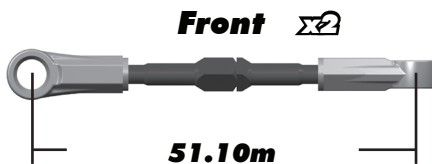

Steering Turnbuckle



:: Front Bulkhead Build - Bag E-EE - Step 1

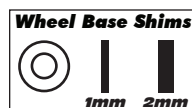
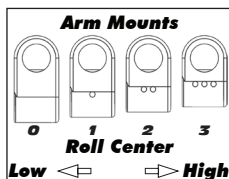
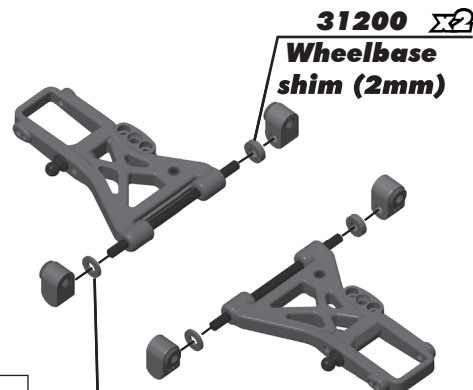
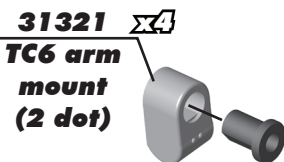
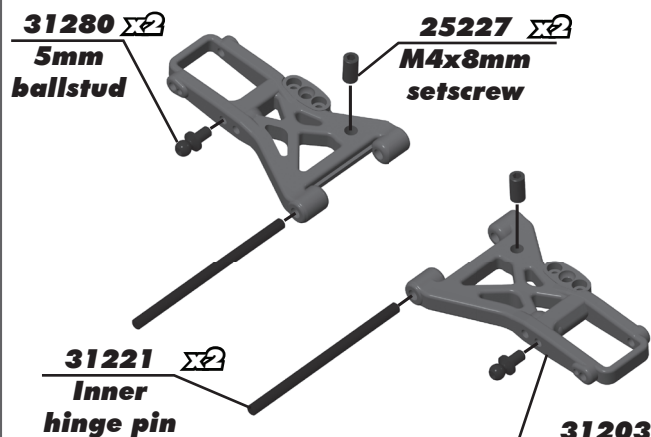

:: Front Bulkhead Build - Bag E-EE - Step 2

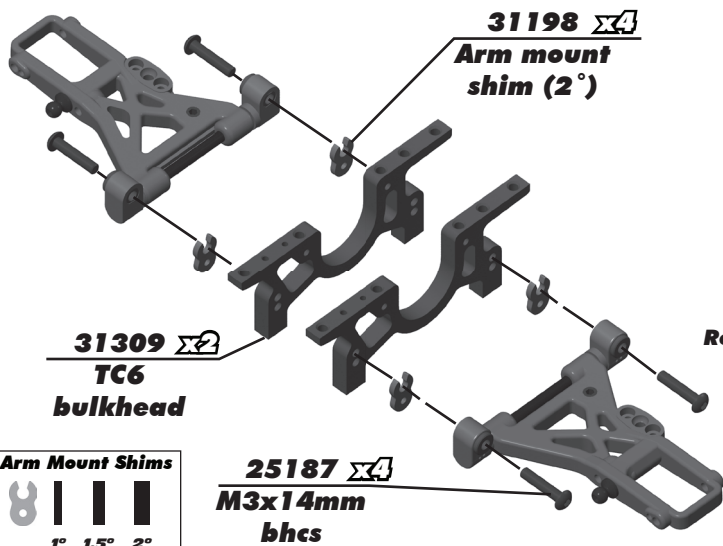

Refer to page 24
for droop
settings!

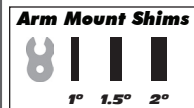
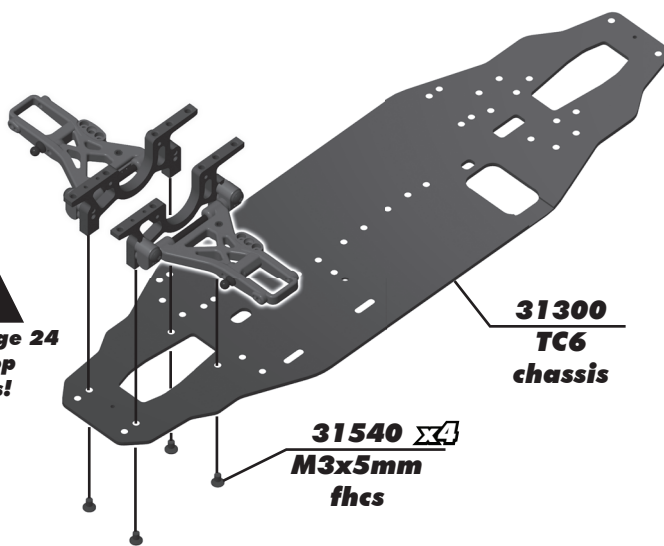

:: Rear Bulkhead Build - Bag E-EE - Step 1

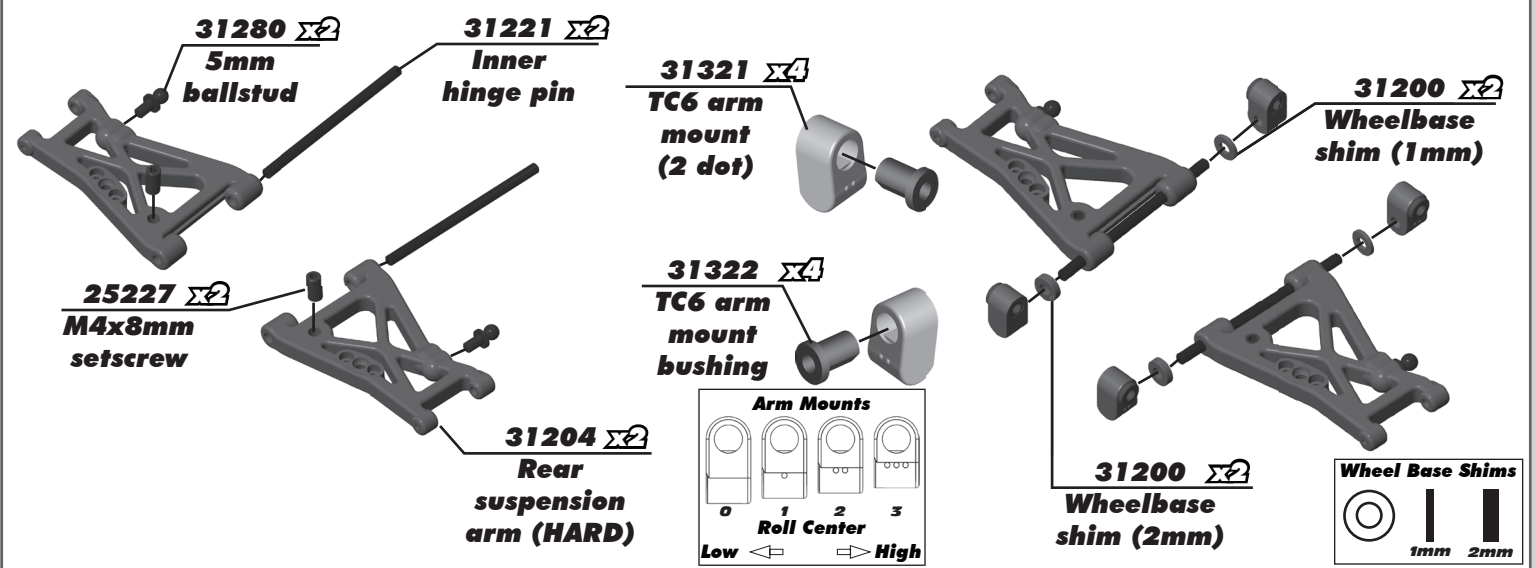

:: Rear Bulkhead Build - Bag E-EE - Step 2

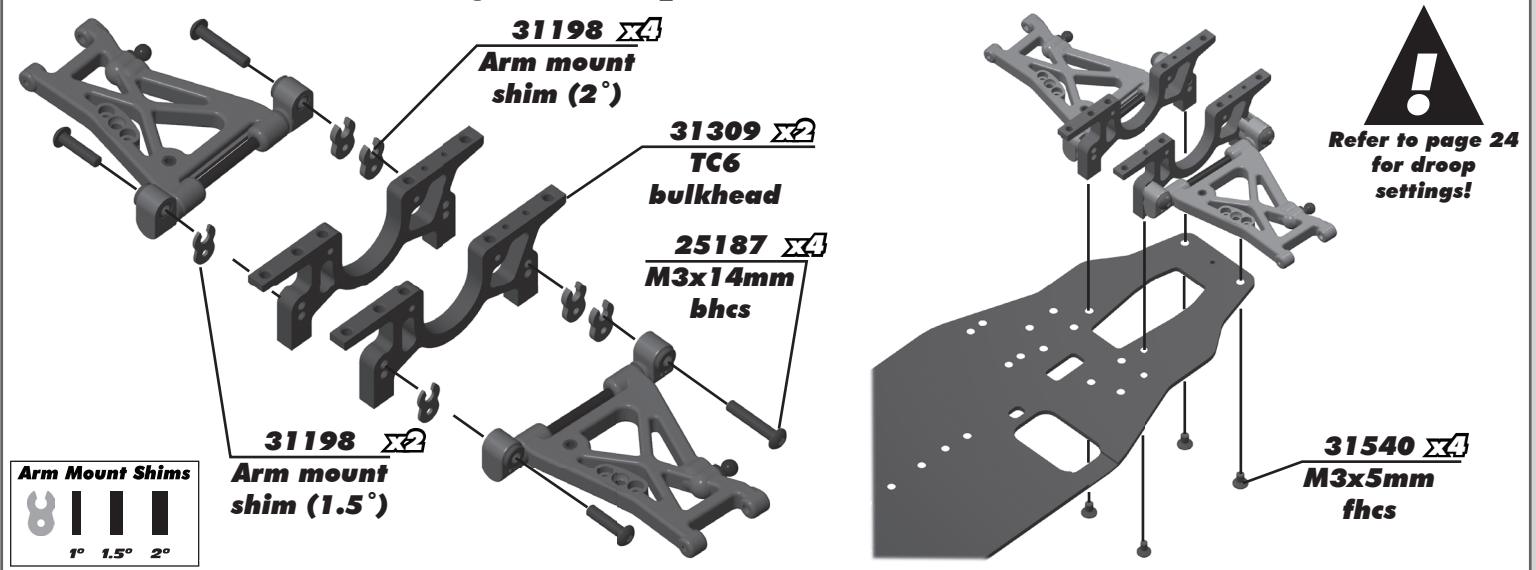

:: Spur Gear Bulkhead / Motor Mount Install - Bag E-EE - Step 1

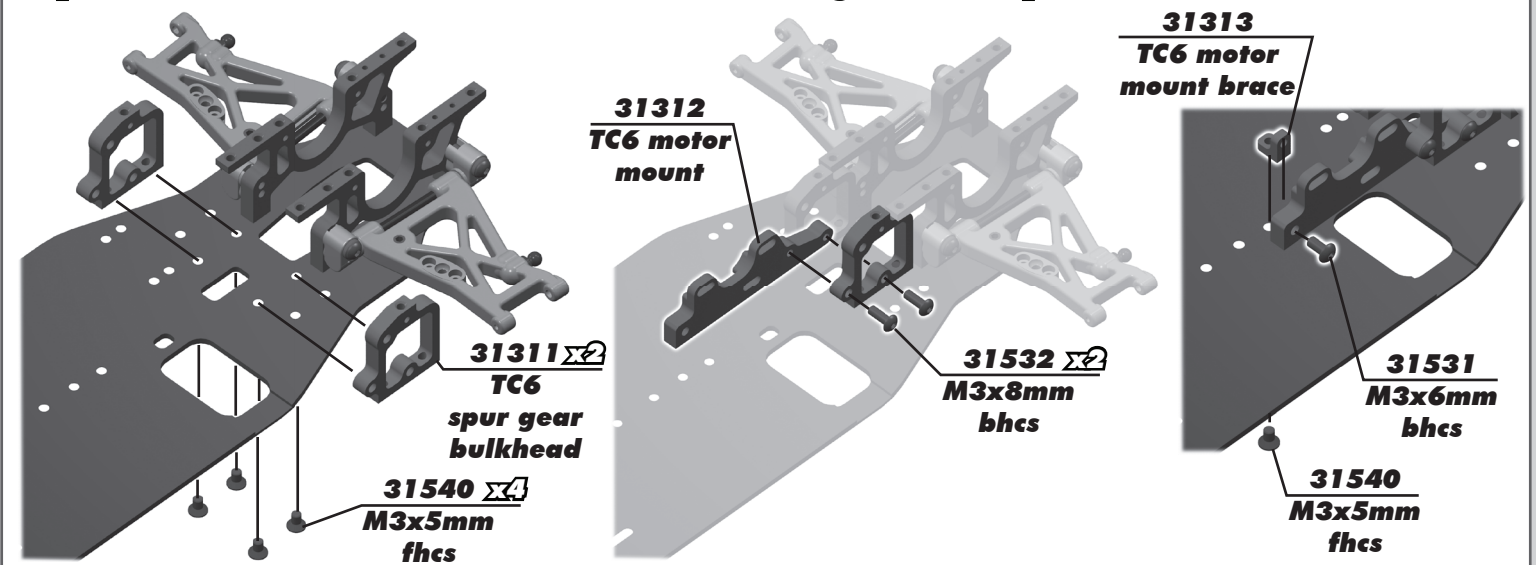

:: Shock Tower Build - Bag E-EE - Step 1

- 31250 Shock bushing
- 31302 TC6 shock tower (front)
- 31541 M3x6mm fhcs
- 2230 Body mounts
- 31250 Shock bushing
- 31310 TC6 bearing cap
- 31310 TC6 bearing cap
- 31281 8mm ballstud
- 31531 M3x6mm bhcs
- 31531 M3x6mm bhcs
- 31541 M3x6mm fhcs
- 31281 8mm ballstud
- 31532 M3x8mm bhcs
- 31303 TC6 shock tower (rear)

! Do not tighten #31541 screws all the way! Leave screws loose until bearing caps are attached to bulkheads!

:: Steering Bellcrank Build / Install - Bag F - Step 1

- 31280 5mm ballstud
- 31308 TC6 bellcrank arm (7mm)
- 31532 M3x8mm bhcs
- 31308 TC6 bellcrank

! Align steering bellcrank to position B for initial setting. Refer to page 23 for Ackermann chart.

Steering Bellcrank

:: Steering Bellcrank Build / Install - Bag F - Step 2

- 31306 TC6 steering bellcrank tube
- 31308 TC6 servo saver arm
- 31280 5mm ballstud
- 31306 TC6 servo saver spring
- 31306 TC6 servo saver nut
- 31307 TC6 steering post
- 31403 4x7mm bearing
- 31307 C-clip

:: Steering Bellcrank Build / Install - Bag F - Step 3

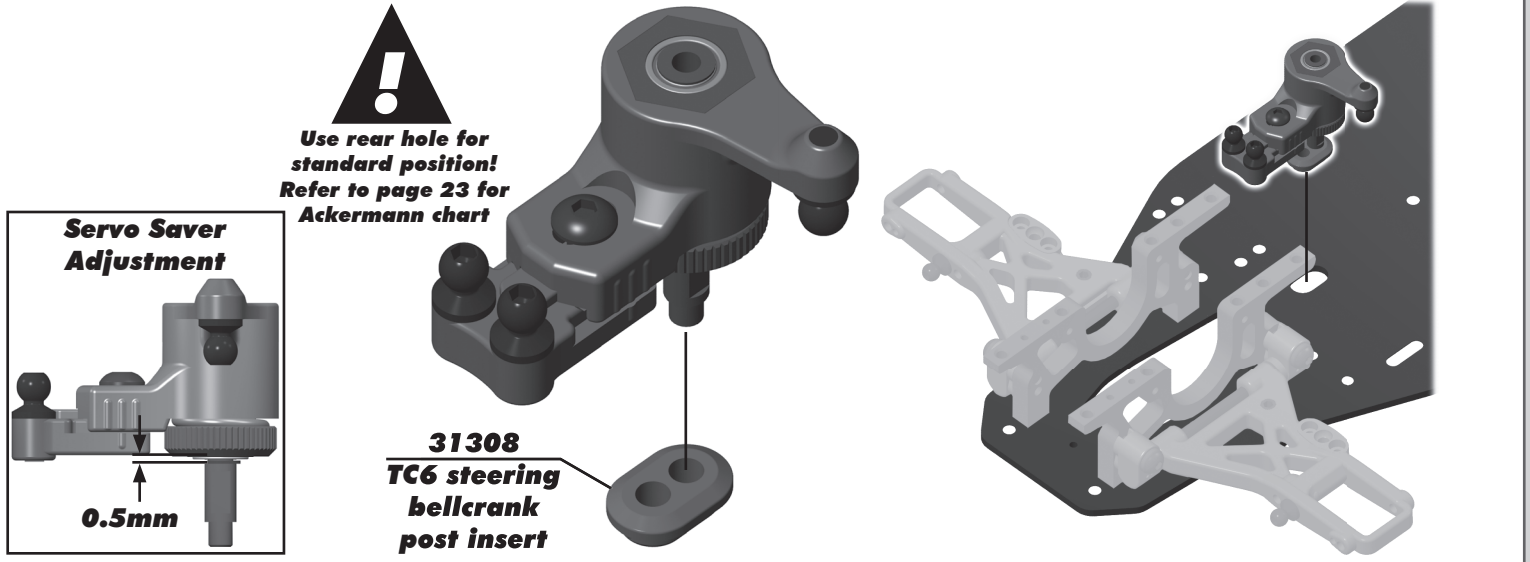

:: Spur Gear Shaft Build - Bag G-GG - Step 1

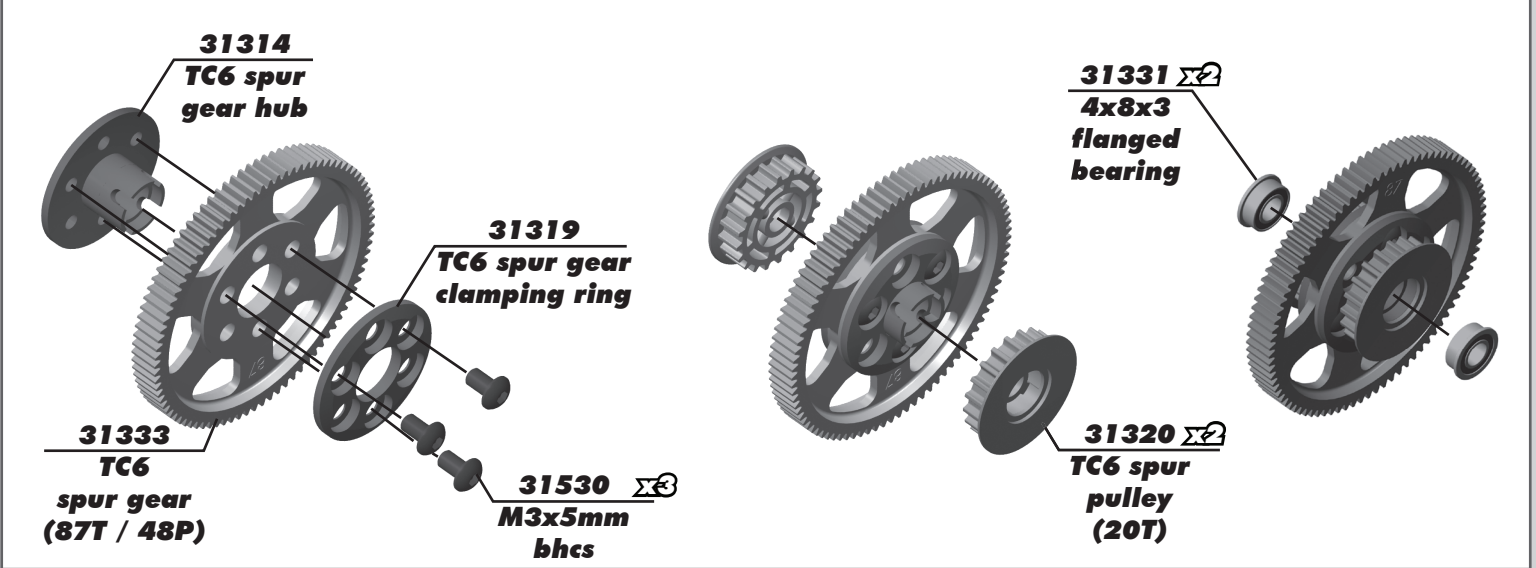

:: Spur Gear Shaft Build - Bag G-GG - Step 2

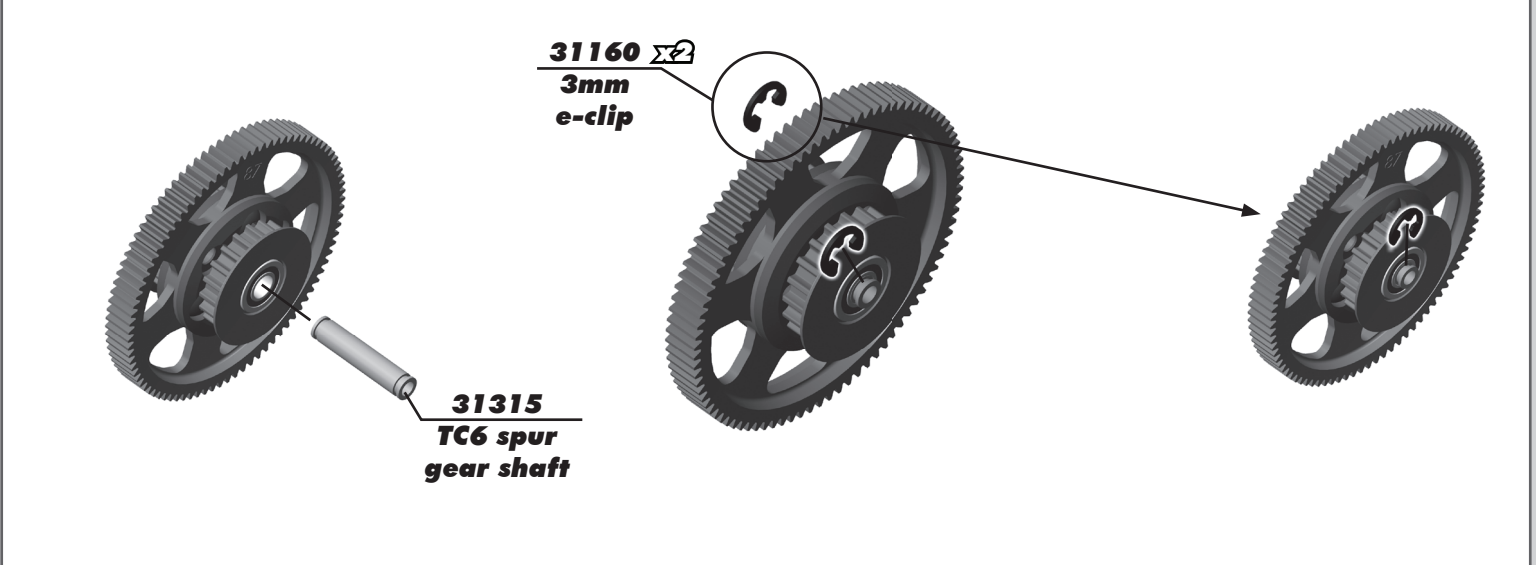

:: Spur Gear Hub / Belts Install - Bag G-GG - Step 1

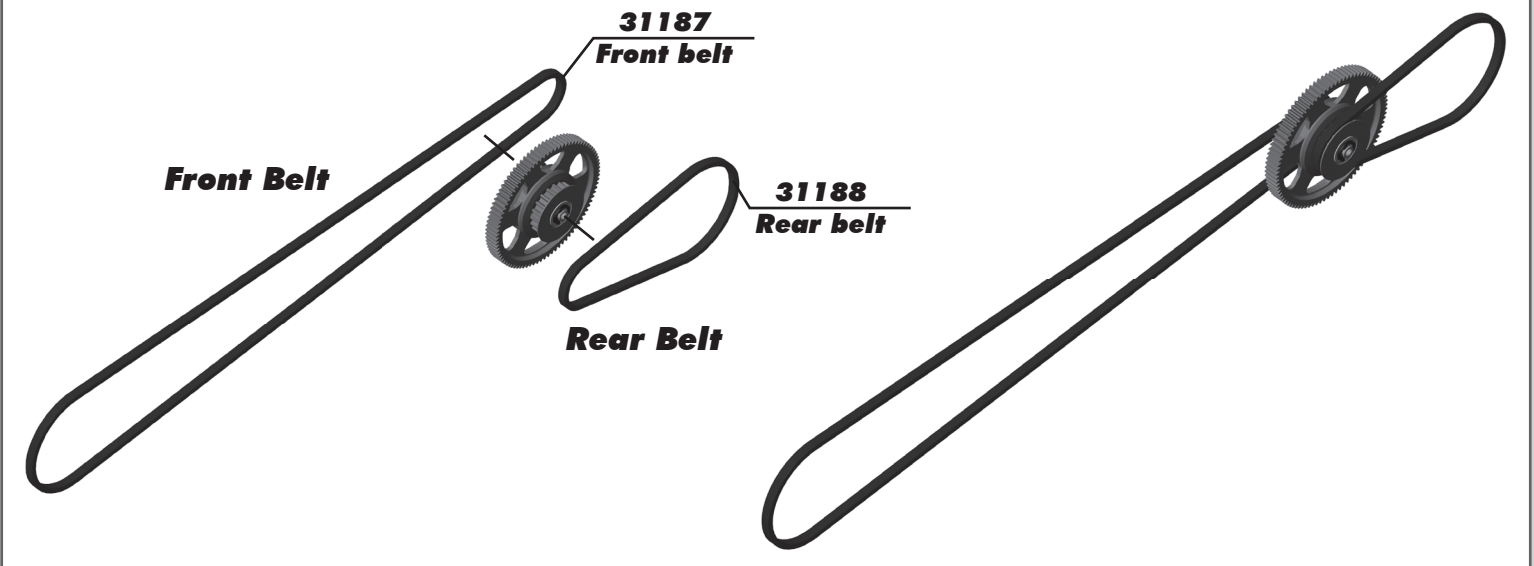

:: Spur Gear Hub / Belts Install - Bag G-GG - Step 2

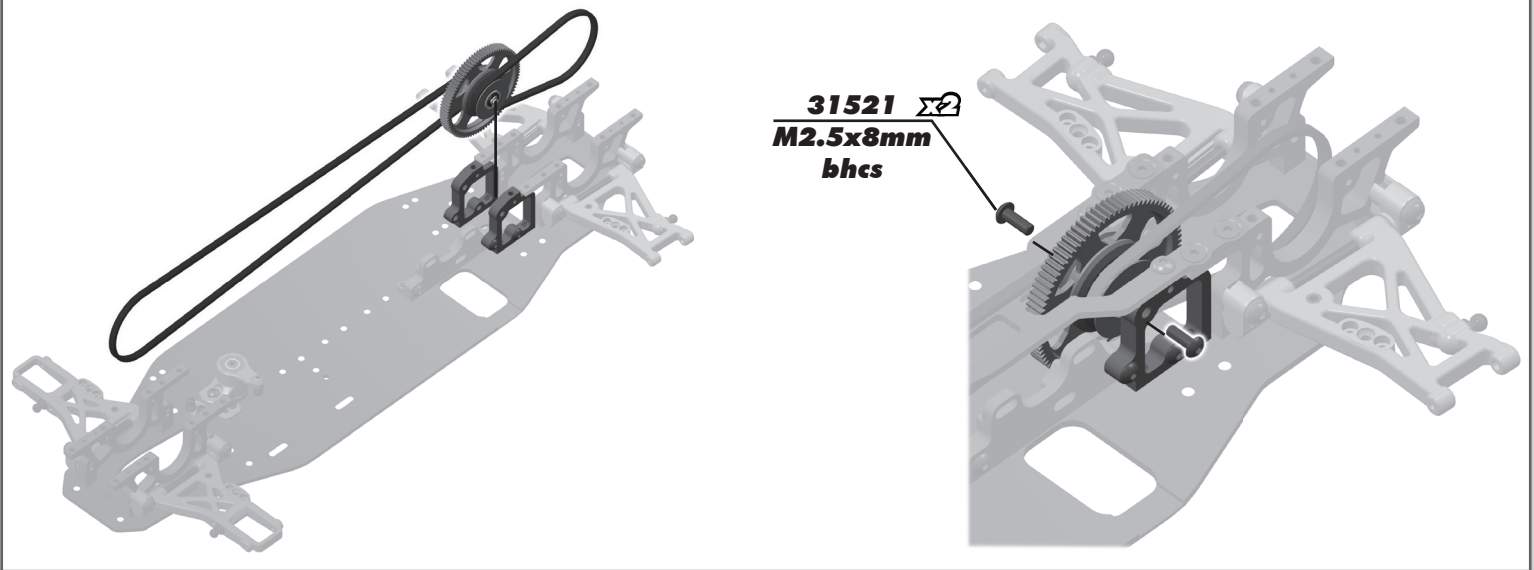

:: Front Slipper Spool Install - Bag G-GG - Step 1

Cam Position

Mid-Low	Mid-High
Low	High

Right Side

31185 $\Sigma 2$
Diff bearing cam (mid-high)

31184 $\Sigma 2$
Cam holder

Left Side

!

Use belt tension position 28 for standard setup.

Note!
Always use the same cam position on both sides of the vehicle.

:: Front Slipper Spool Install - Step 2 / Rear Differential Install - Bag G-GG - Step 1

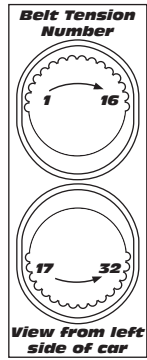
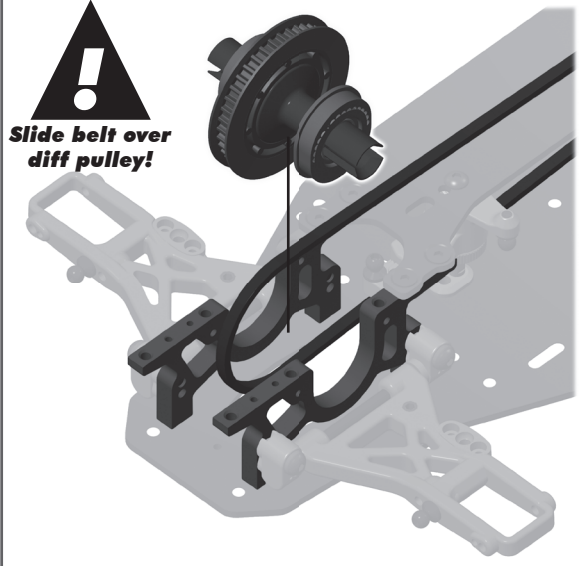

!
Use belt tension position 6 for standard setup.

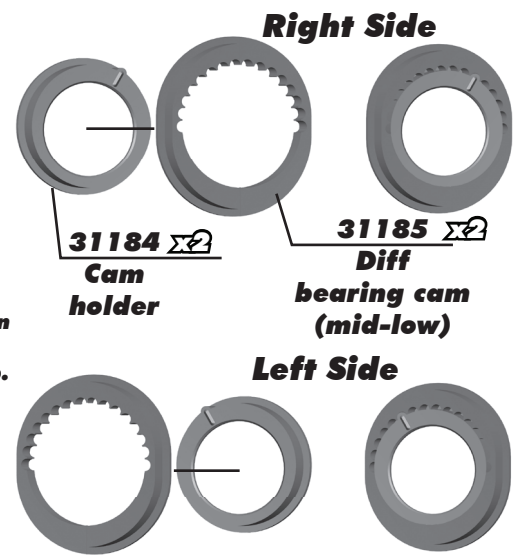

:: Rear Differential Install - Bag G-GG - Step 2

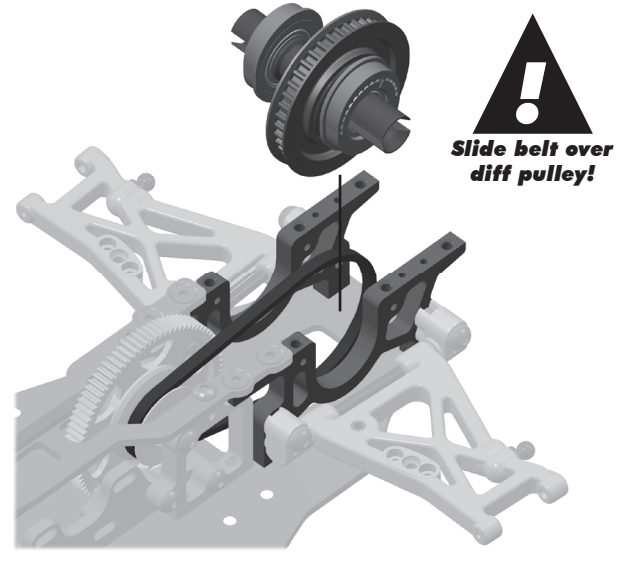
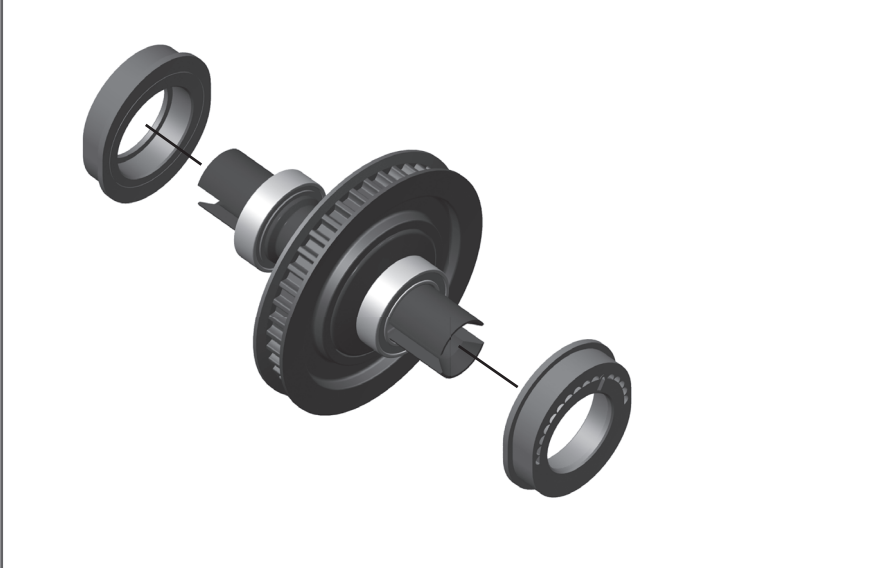

:: Top Plate / Bearing Caps Install - Bag G-GG - Step 1

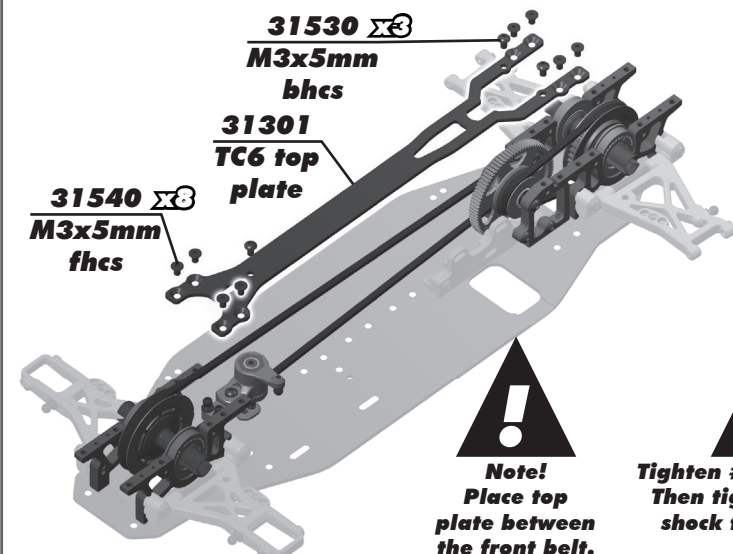

!
Note! Place top plate between the front belt.

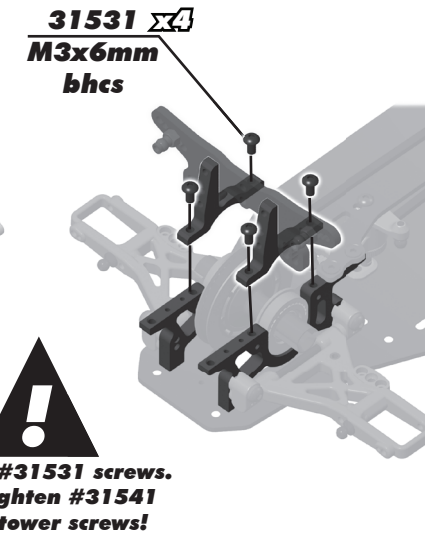

!
Tighten #31531 screws. Then tighten #31541 shock tower screws!

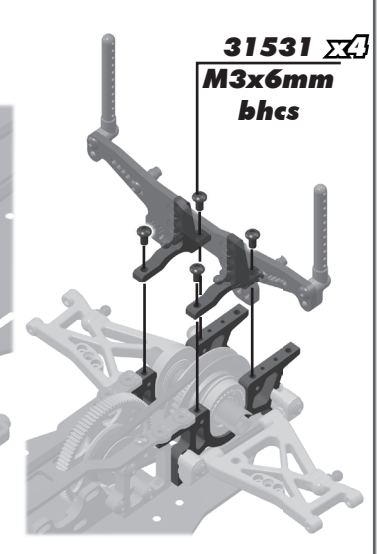

:: Steering Block Build / Install - Bag H - Step 1

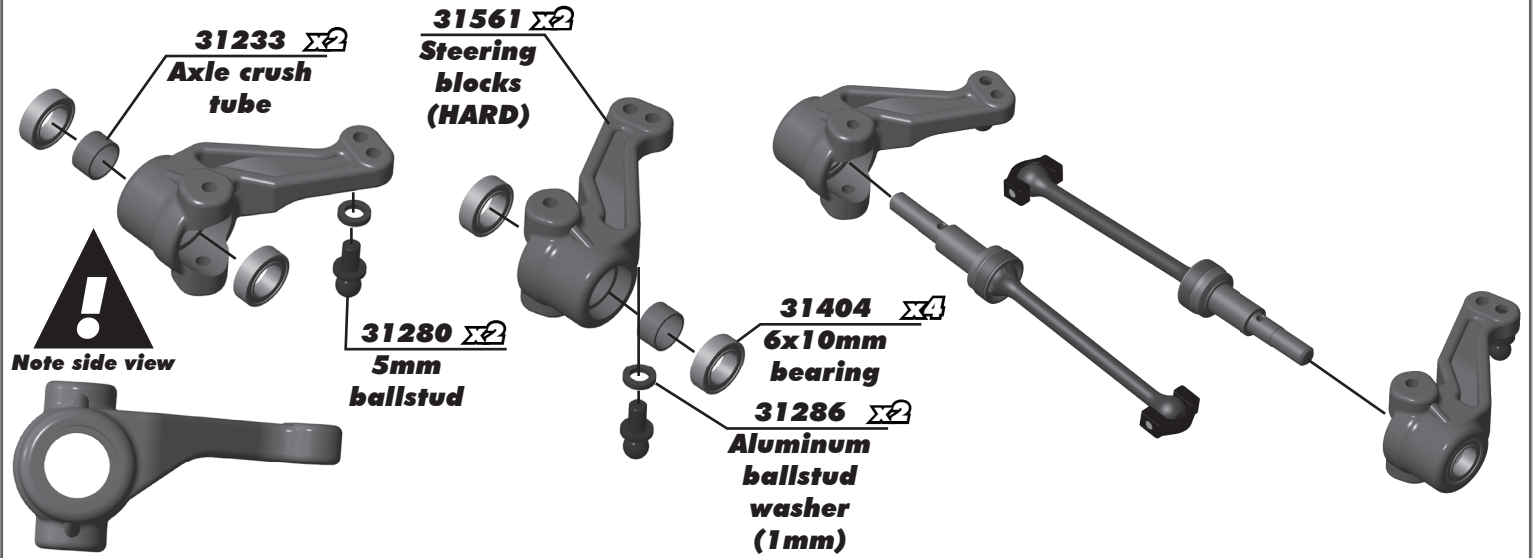

:: Steering Block Build / Install - Bag H - Step 2

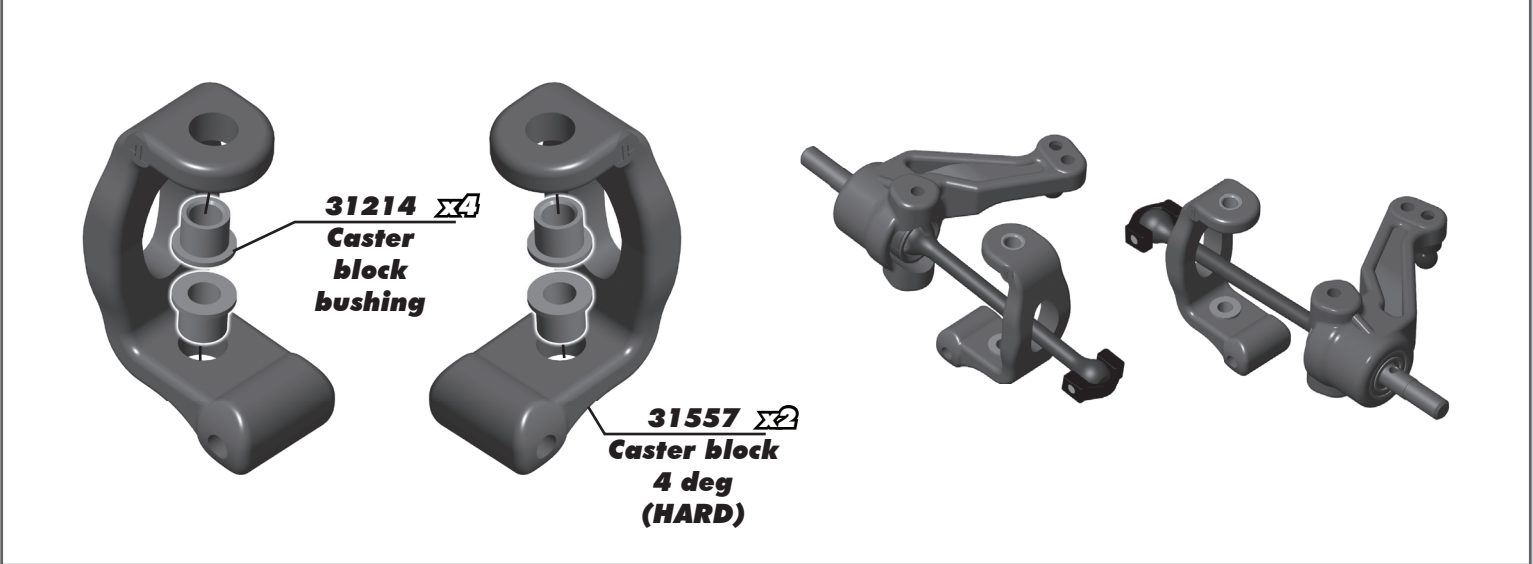

:: Steering Block Build / Install - Bag H - Step 3

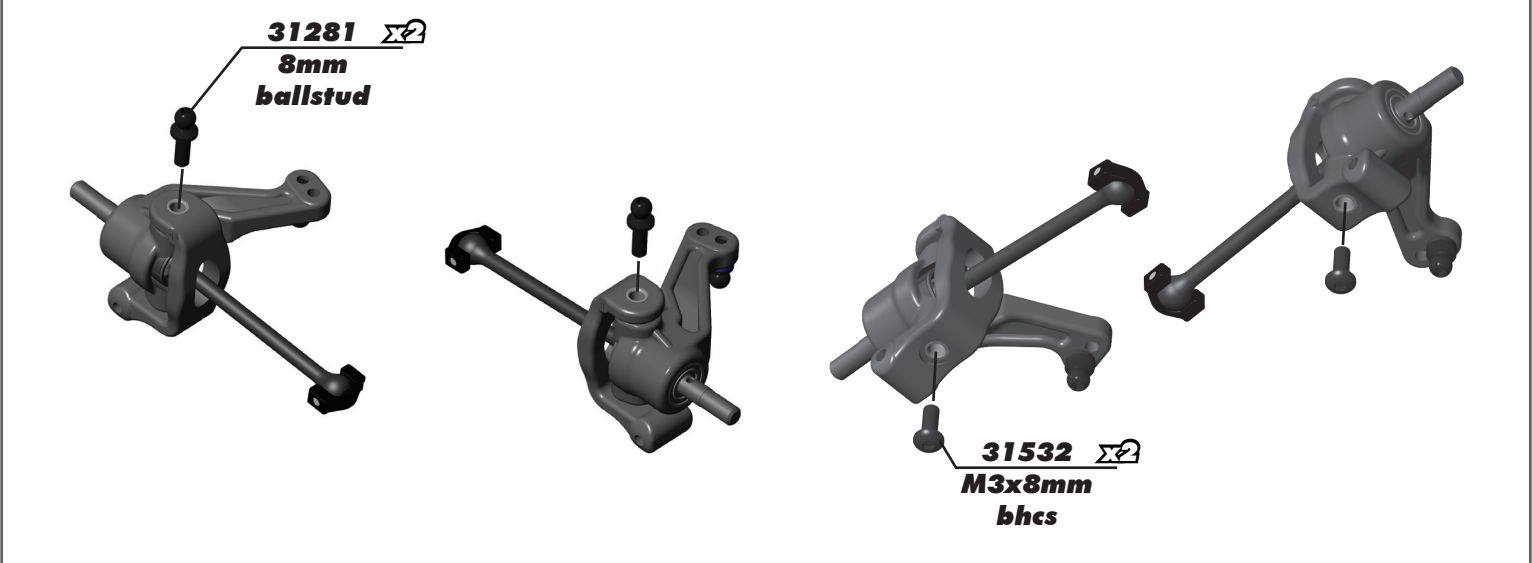

:: Steering Block Build / Install - Bag H - Step 4

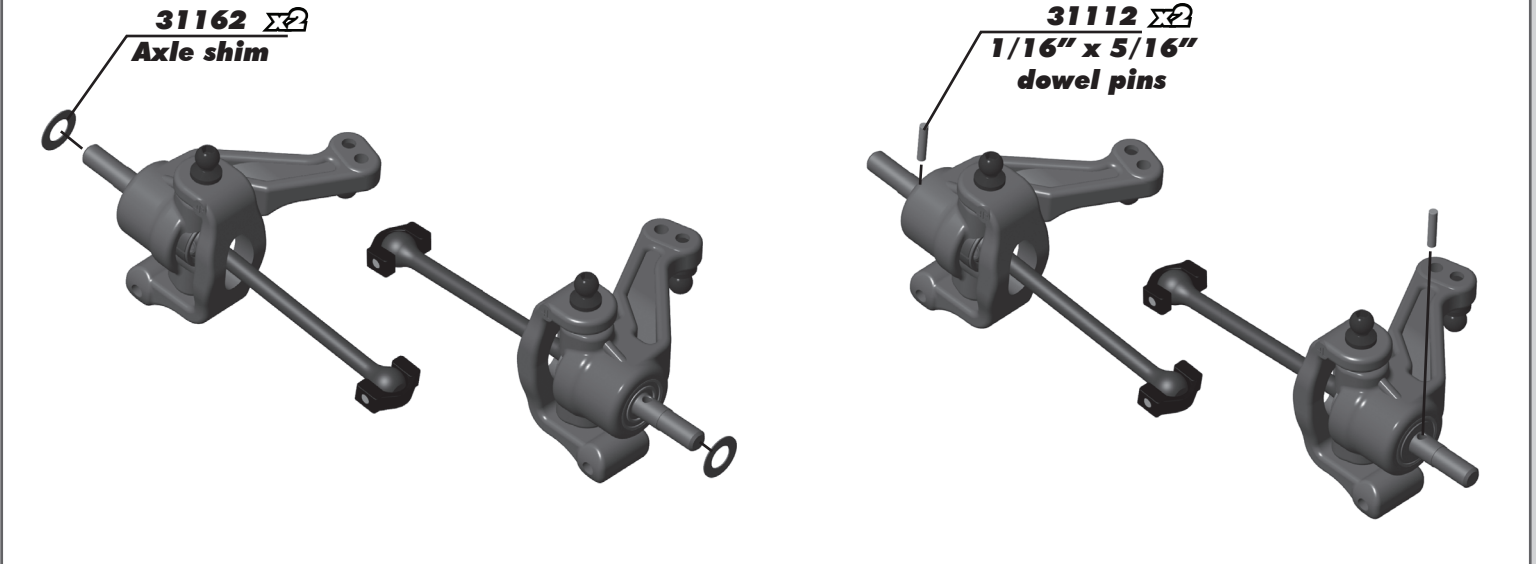

:: Steering Block Build / Install - Bag H - Step 5

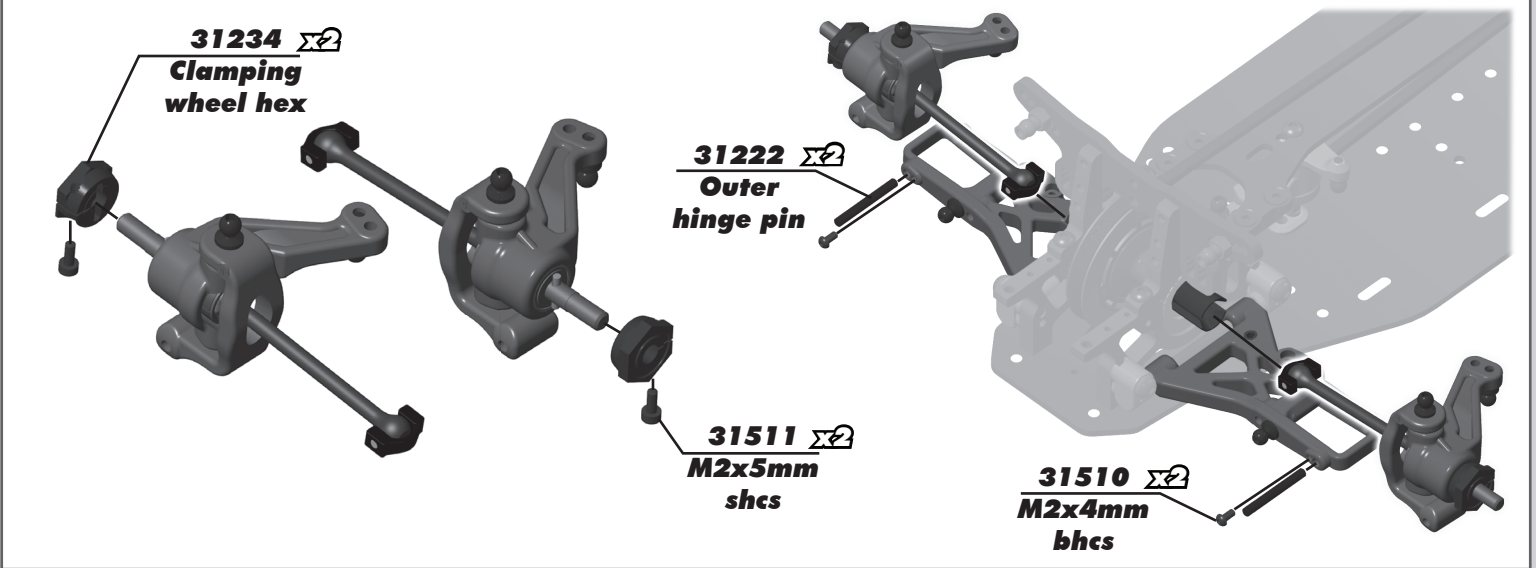

:: Steering Block Build / Install - Bag H - Step 6

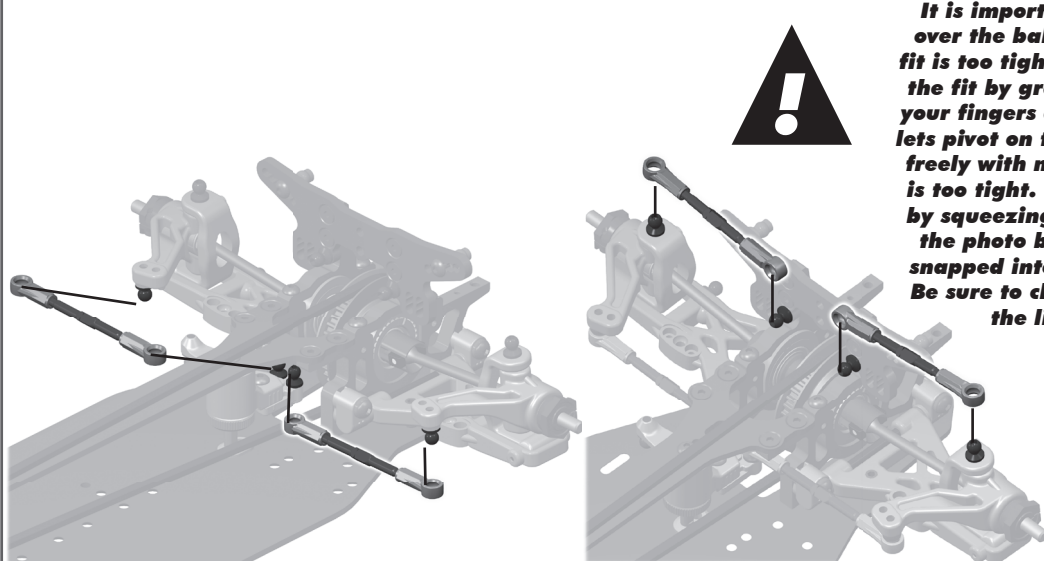

It is important that the turnbuckle eyelets fit freely over the ball studs after they are snapped on. If the fit is too tight, car handling will be inconsistent. Check the fit by grabbing onto the installed turnbuckle with your fingers and twisting it so that the turnbuckle eyelets pivot on the ball studs. The turnbuckle should twist freely with no resistance. If there is resistance, the fit is too tight. The turnbuckle eyelet fit can be loosened by squeezing it with a needle-nose pliers, as shown in the photo below. It is important that a ball stud be snapped into the turnbuckle eyelet before squeezing! Be sure to check and adjust the fit for each end of all the links that are added to the chassis.



:: Rear Hubs Build / Install - Bag H - Step 1

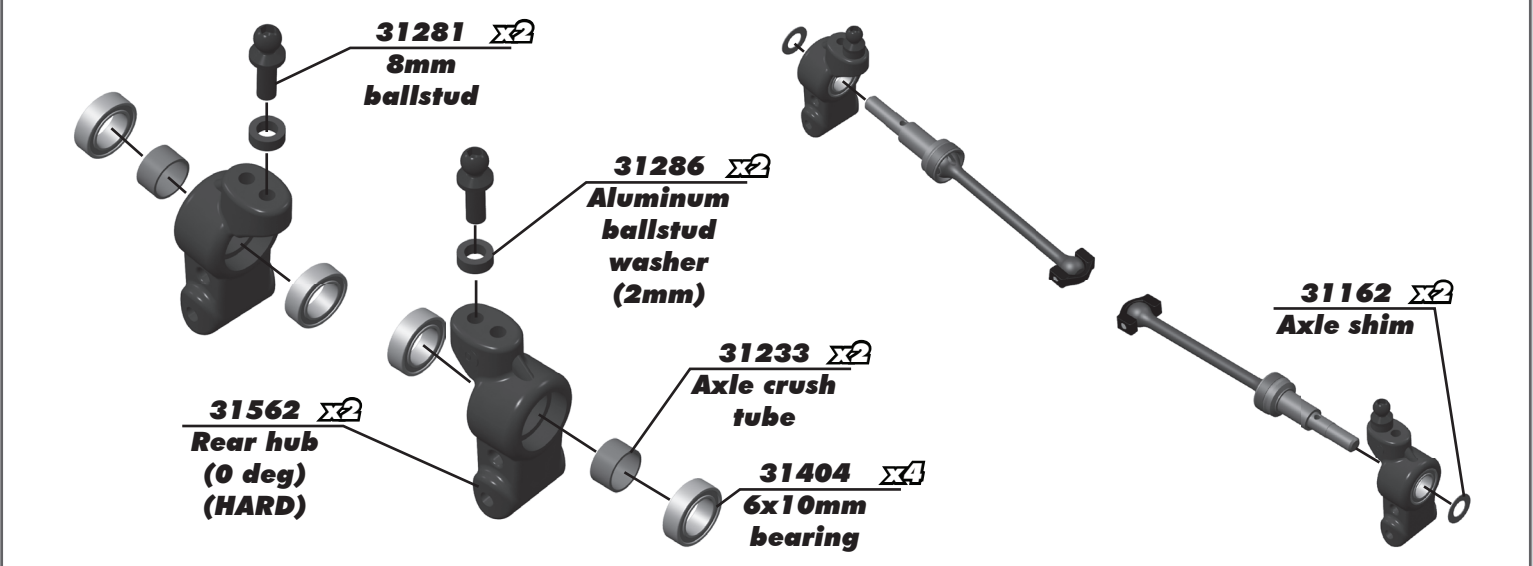

:: Rear Hubs Build / Install - Bag H - Step 2

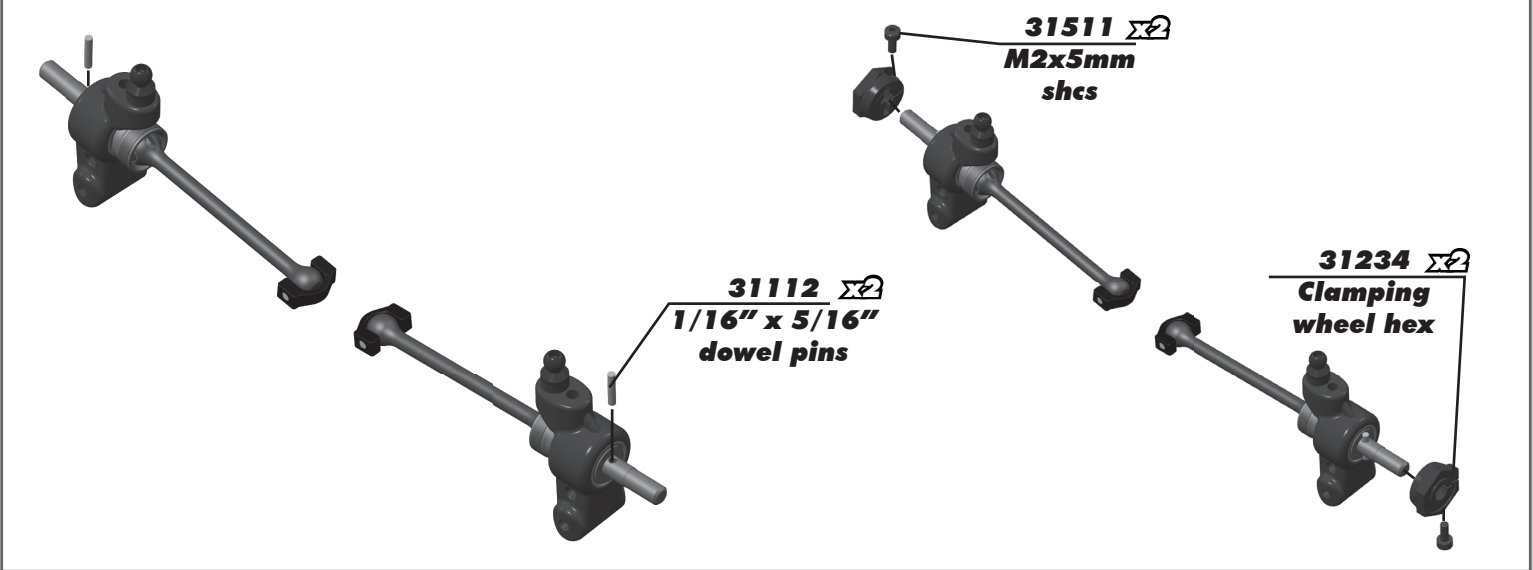

:: Rear Hubs Build / Install - Bag H - Step 3

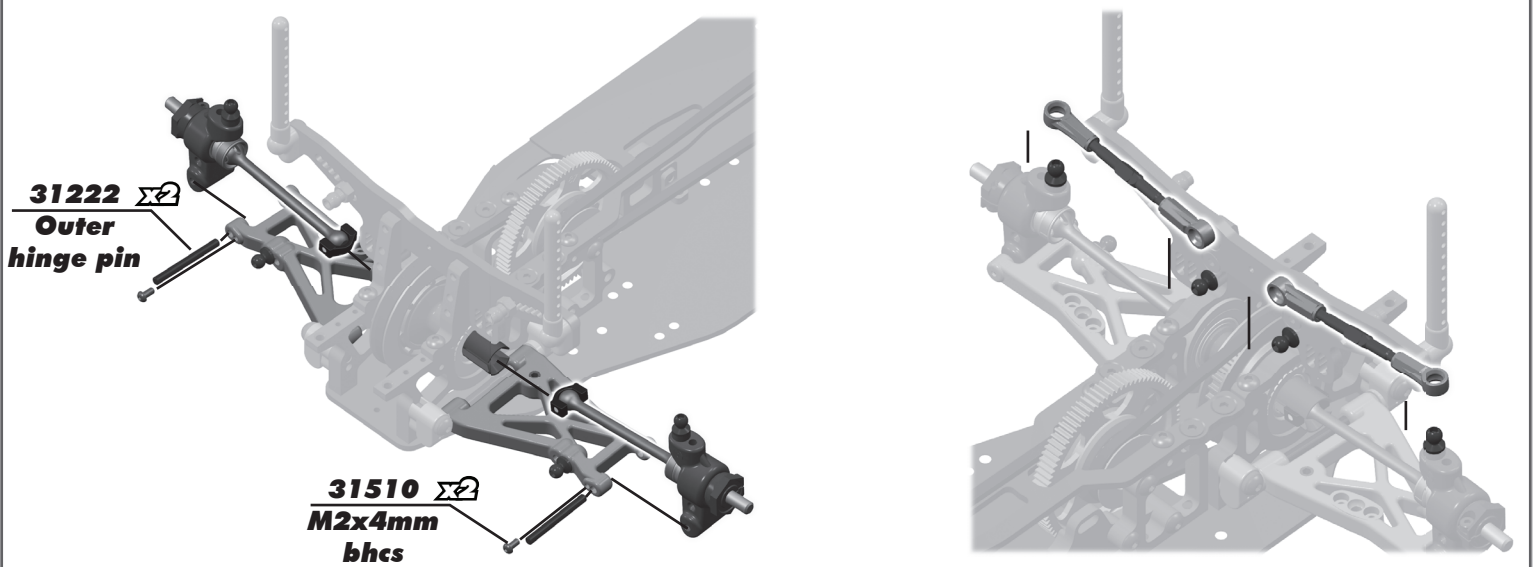

:: Shocks Install - Bag H - Step 1

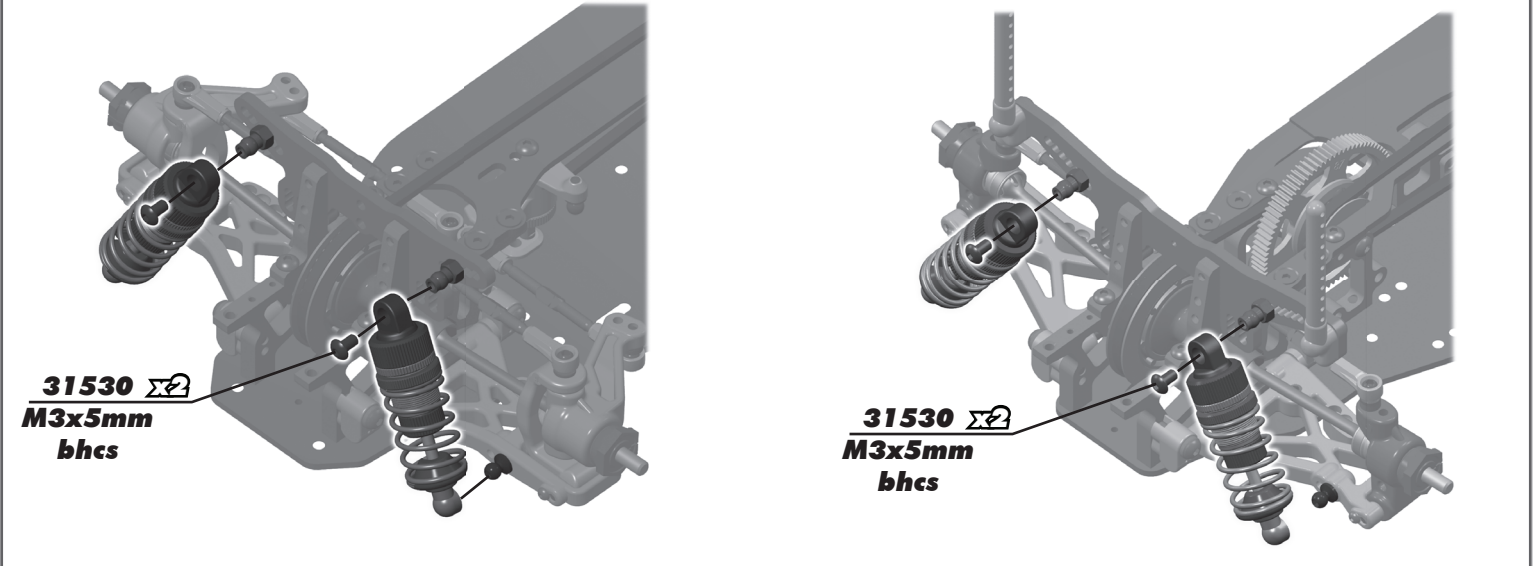

:: Bumper Build / Install - Bag I - Step 1

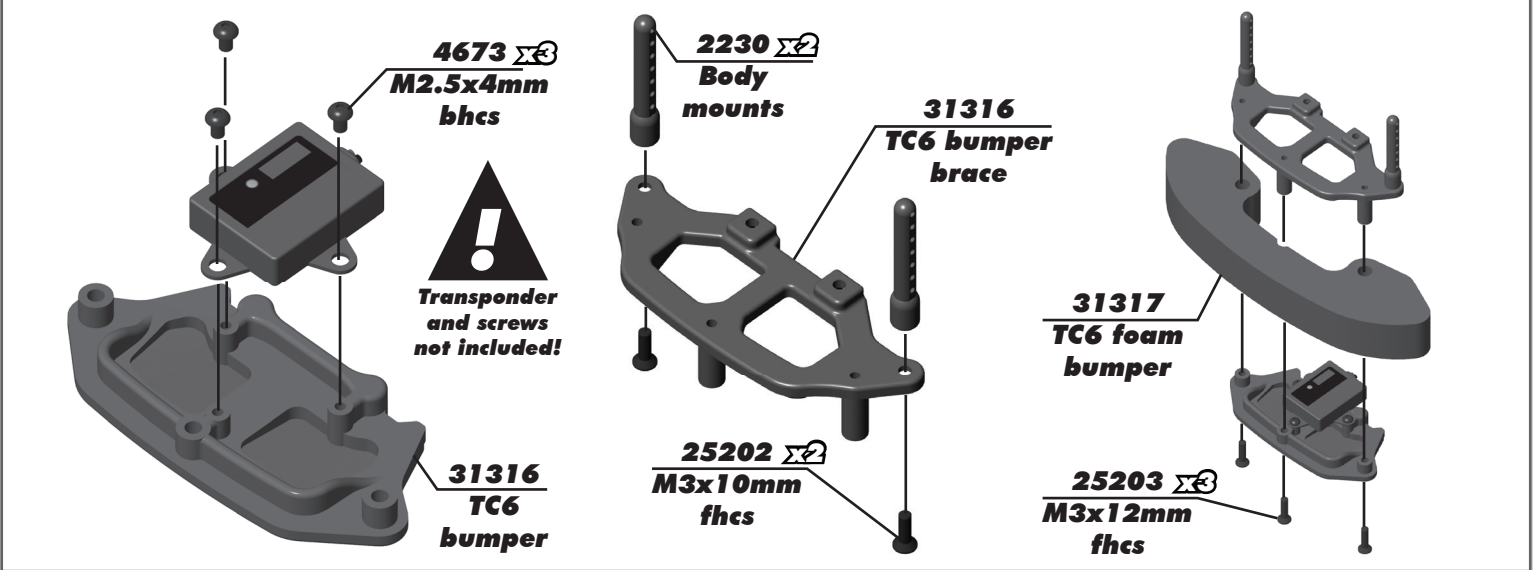

:: Bumper Build / Install - Bag I - Step 2

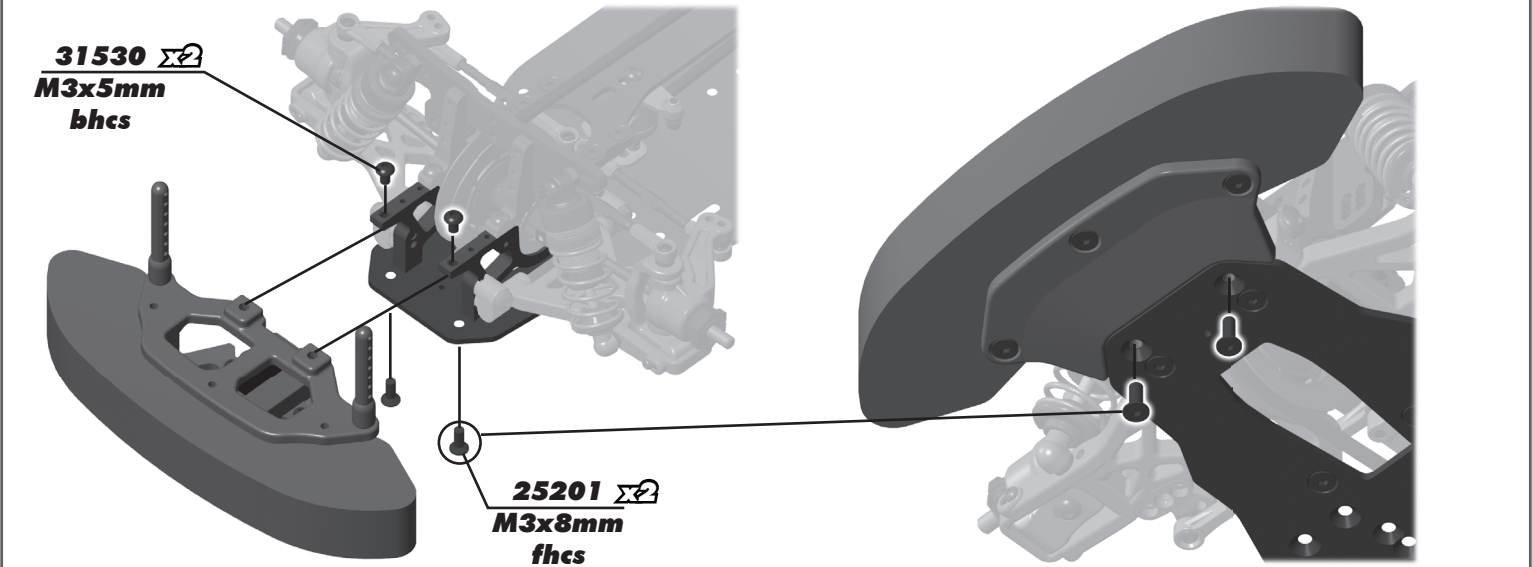

:: Pivoting Body Mounts Install - Bag I - Step 1

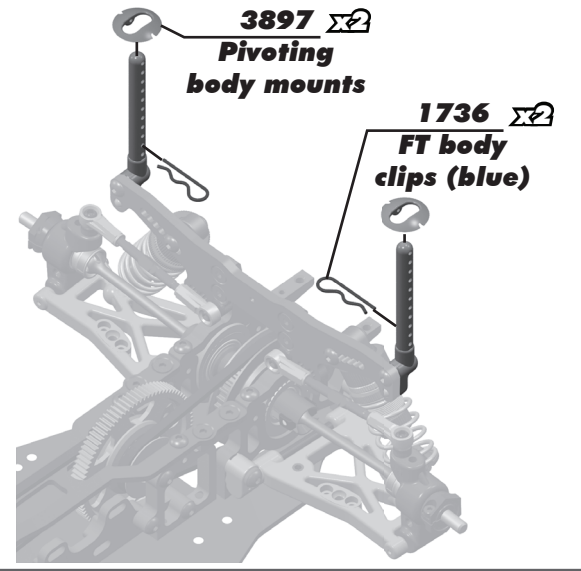
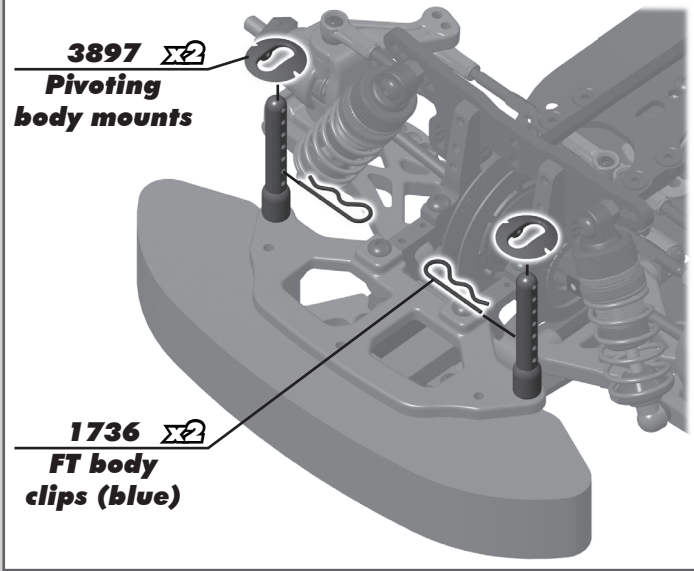

:: Battery Braces / Antenna Mount Install - Bag I - Step 1

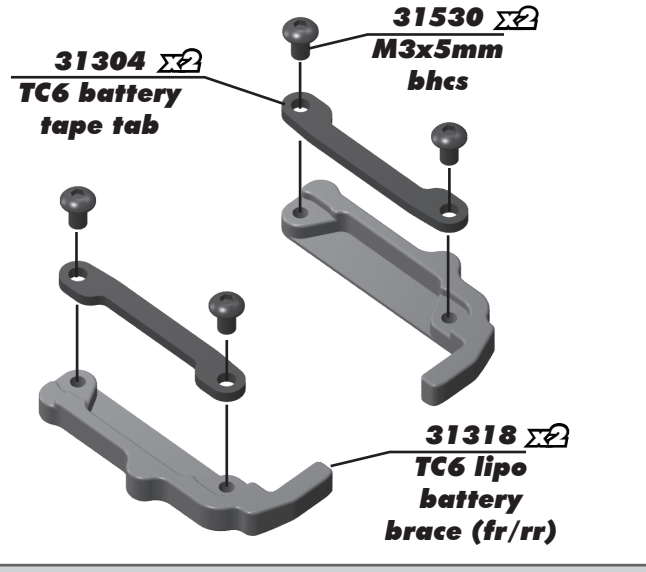
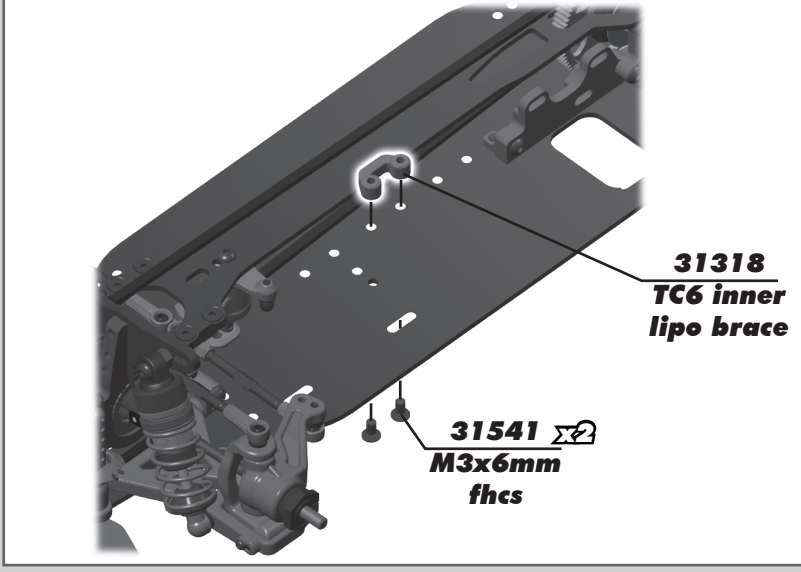

:: Battery Braces / Antenna Mount Install - Bag I - Step 2

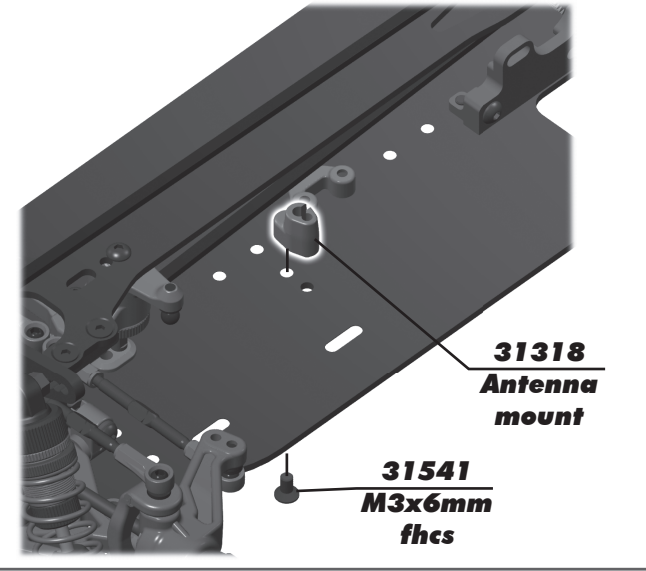
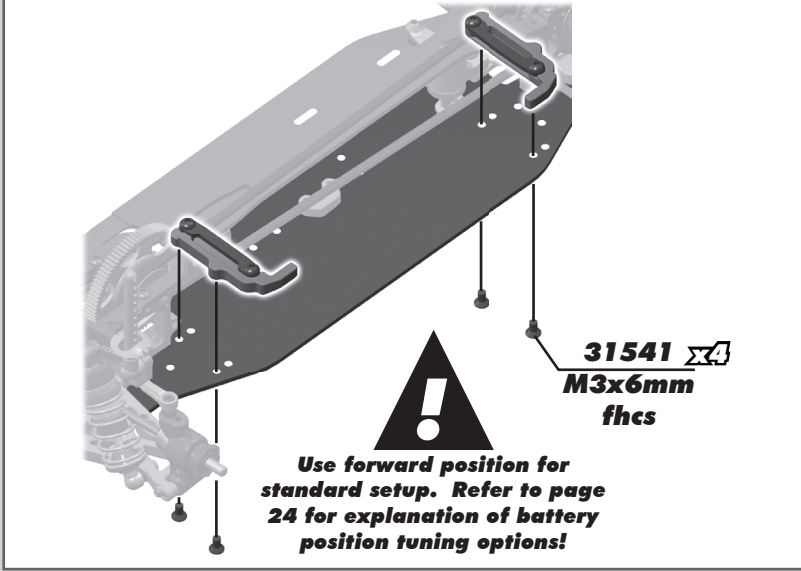

:: Anti-Roll Bars Build / Install - Bag J - Step 1



Build four anti-roll bar mounts

Anti Roll Bar Link Adjustment

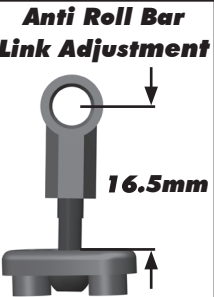

16.5mm

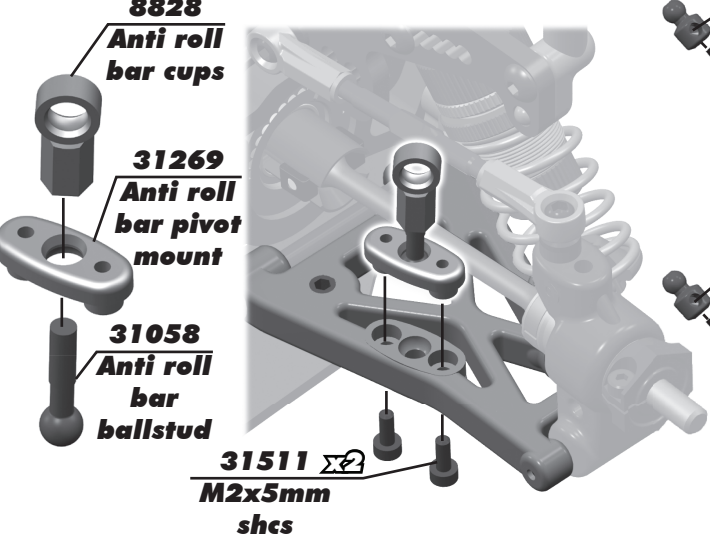

8828
Anti roll bar cups

31269
Anti roll bar pivot mount

31058
Anti roll bar ballstud

31511 $\Sigma 2$
M2x5mm shcs

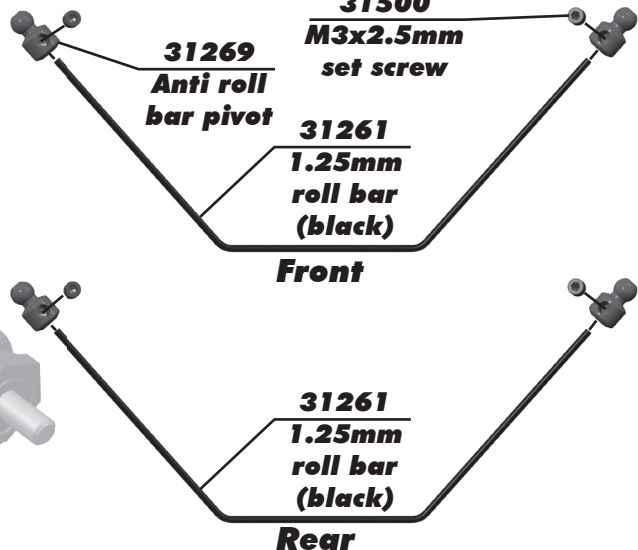

31500
M3x2.5mm set screw

31269
Anti roll bar pivot

31261
1.25mm roll bar (black)

Front



31261
1.25mm roll bar (black)

Rear

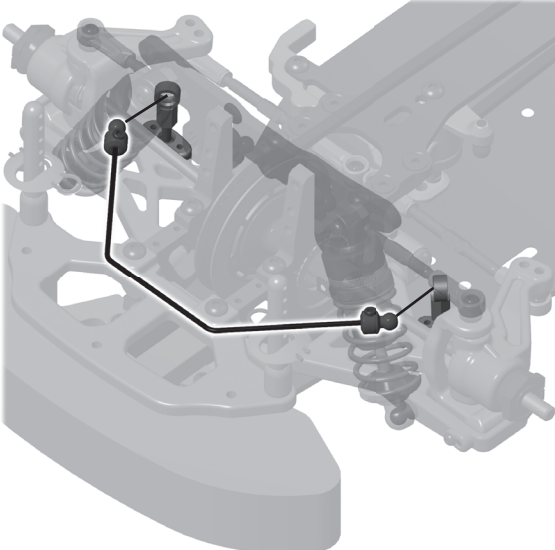
:: Anti-Roll Bars Build / Install - Bag J - Step 2



Anti-Roll Bar Mount System

-  1 dot: 1.25mm (black)
-  2 dot: 1.50mm (silver)
-  3 dot: 1.75mm (gold)

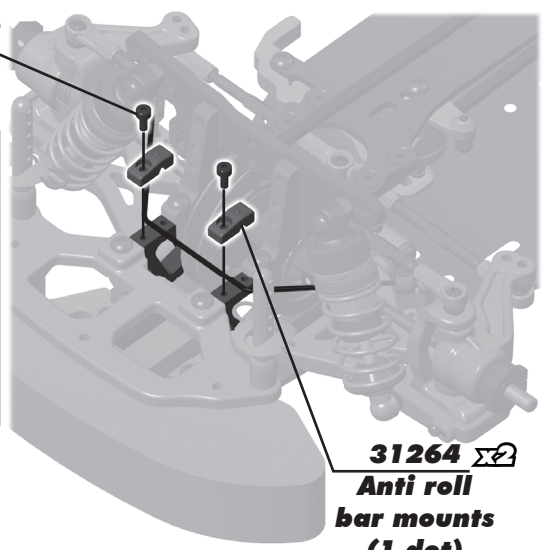



31511 $\Sigma 2$
M2x5mm shcs

31264 $\Sigma 2$
Anti roll bar mounts (1 dot)

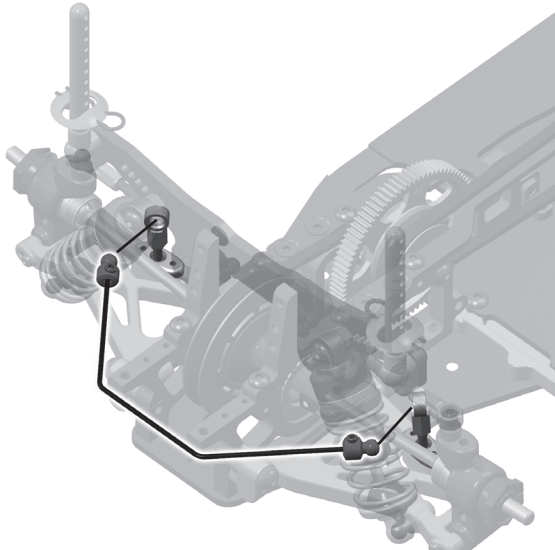
:: Anti-Roll Bars Build / Install - Bag J - Step 3



Anti-Roll Bar Mount System

-  1 dot: 1.25mm (black)
-  2 dot: 1.50mm (silver)
-  3 dot: 1.75mm (gold)

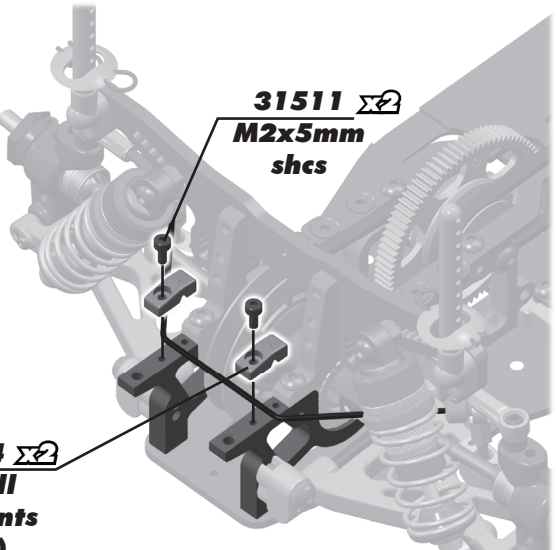

31511 $\Sigma 2$
M2x5mm shcs

31264 $\Sigma 2$
Anti roll bar mounts (1 dot)

:: Servo Build / Install - Bag K - Step 1

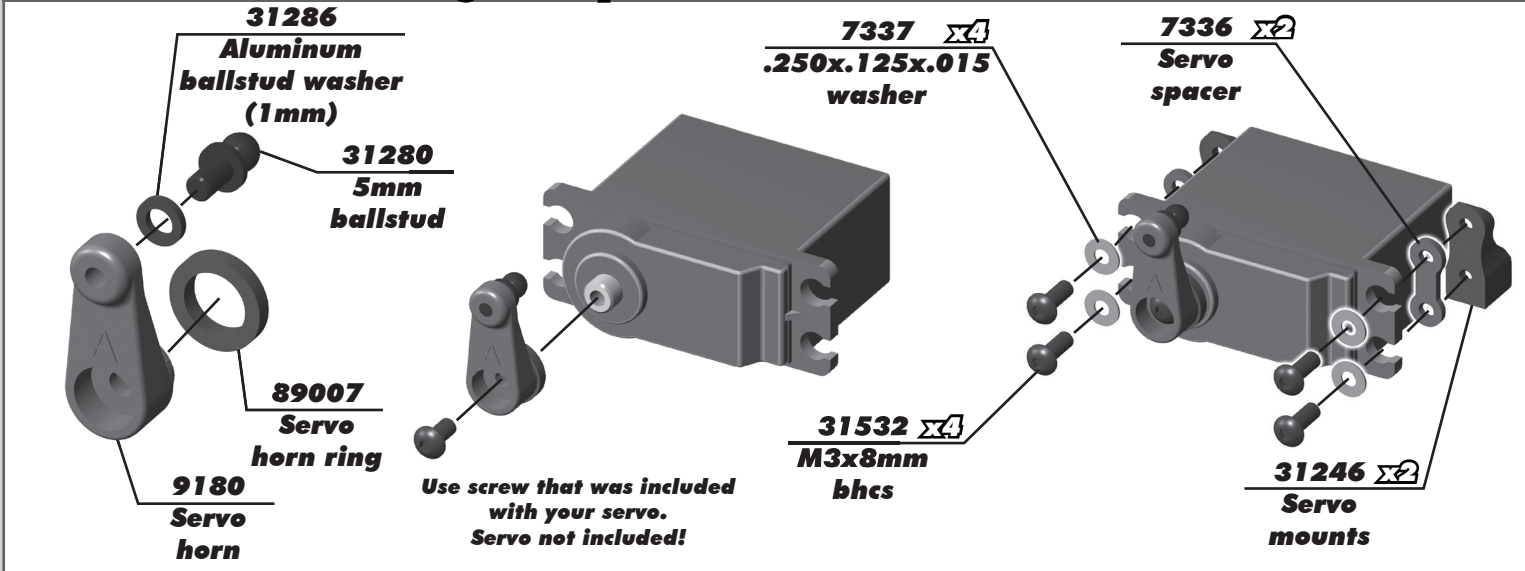

:: Servo Build / Install - Bag K - Step 2

Steering Servo Chart

		# 9180 servo arm
Associated	XP-1015, XP-1313	F
Airtronics	94102	A
Airtronics	94738, 94157, 94158, 94257, 94258, 94357, 94358, 94452, 94453, 94751, 94755	A
Hitec	HS-5625MG, HS-5645MG, HS625MG, HS645MG	H
Hitec	HS-322HD, HS-325HB, HS-965, HS-985MG, HS-5965, HS-5985MG, HS-425BB, HS-422	H
JR	Z4725, Z4750, Z2750, Z8450, Z8550, NES-4750	J
JR	Z250, Z550	J
Futaba	S9204, S9250, S9450, S148	F
Futaba	S3003, S9202, S9101	F
Futaba	S9404	F
KO	PS-401, PS-2001, PS-2004, PS-2015, PS-2173, PS-2174, PS-2123, PS-2143, PS-2144	J

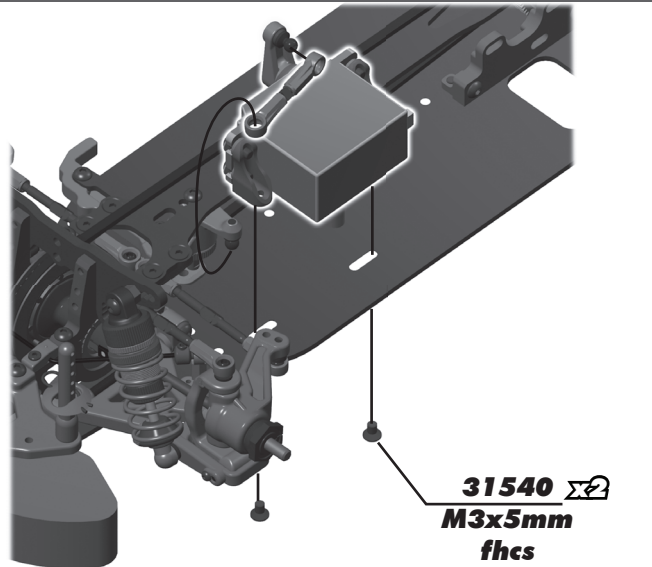

* Not all servo's are listed

* Make sure servo linkage clears the servo through full travel in both directions. Use #7336 servo spacers to adjust servos position

:: Electronics Install - Bag L - Step 1

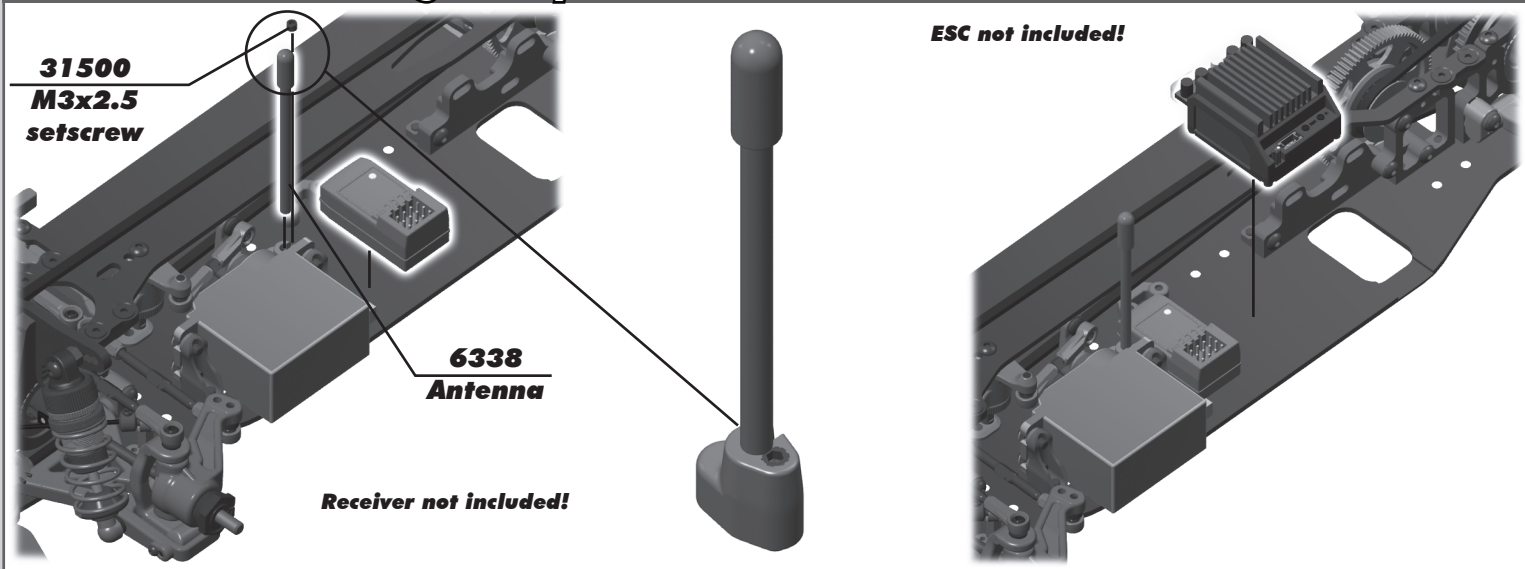

:: Electronics Install - Bag L - Step 2



Gearing will depend on the motor and track size.
 Motor, pinion gear, and set screw are not included!

31286 
 Aluminum ballstud washer (1mm)
31531 
 M3x6mm bhcs

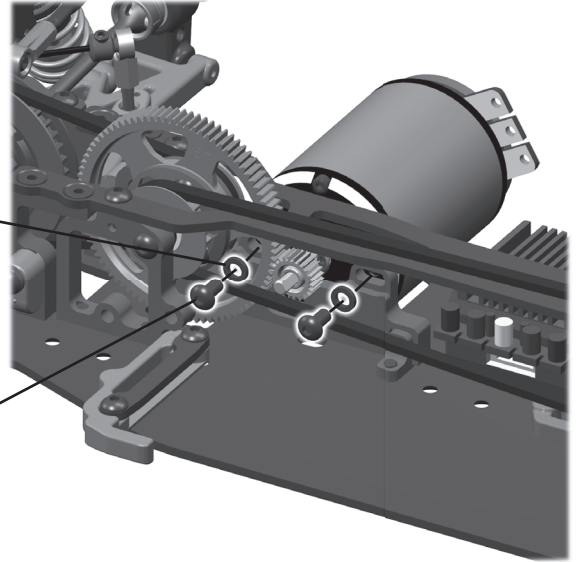

:: Electronics Install - Bag L - Step 3

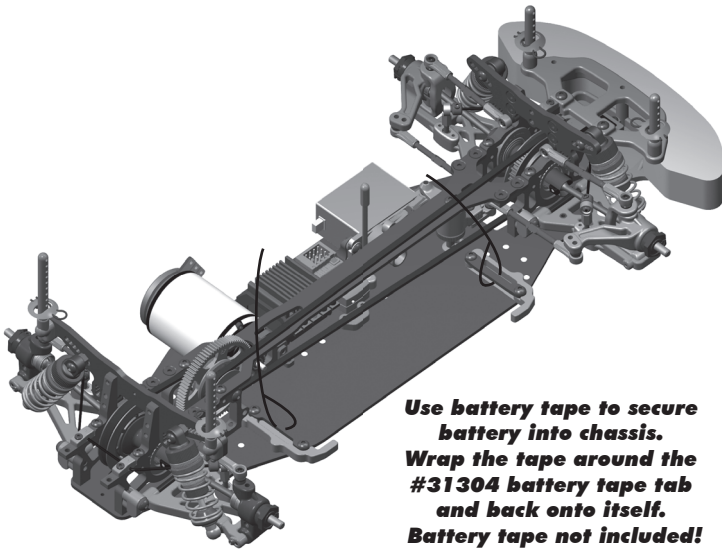

Use battery tape to secure battery into chassis.
 Wrap the tape around the #31304 battery tape tab and back onto itself.
 Battery tape not included!

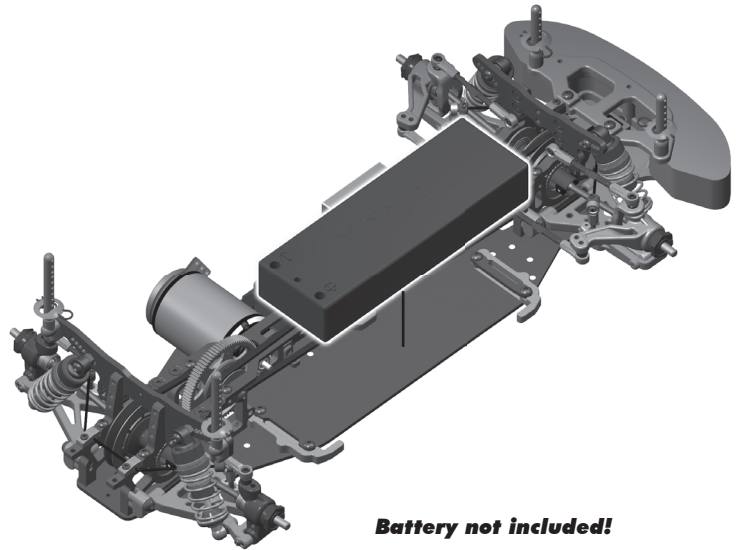

Battery not included!

:: Wheel & Tire Build / Install - Bag L - Step 4

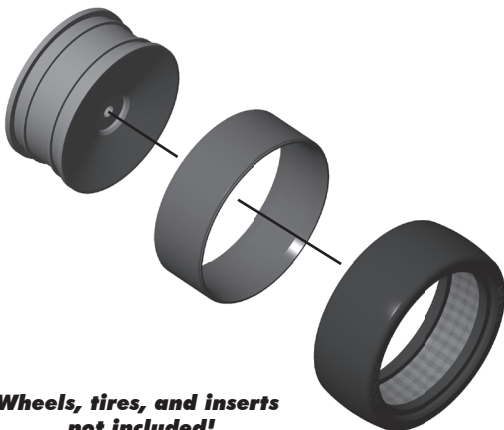

Wheels, tires, and inserts not included!

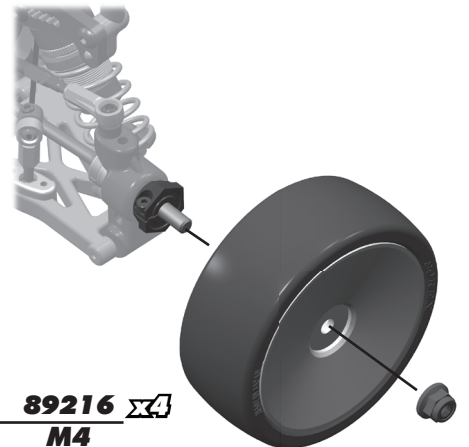
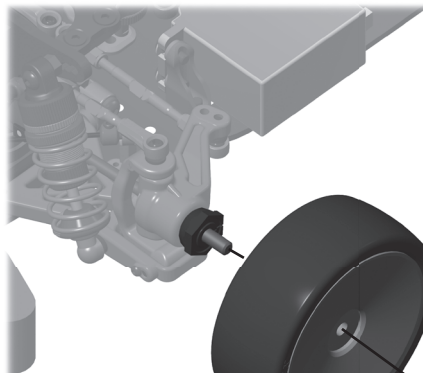

89216 
 M4 locknut

:: Tuning Tips

Tips for Beginners:

Before making any changes to the standard setup, make sure you can get around the track without crashing. Changes to your car will not be beneficial if you can't stay on the track. Your goal is consistent laps.

Once you can get around the track consistently, start tuning your car. Make only ONE adjustment at a time, testing it before making another change. If the result of your adjustment is a faster lap, mark the change on the included setup sheet (make additional copies of the sheet before writing on it). If your adjustment results in a slower lap, revert back to the previous setup and try another change.

When you are satisfied with your car, fill in the setup sheet thoroughly and file it away. Use this as a guide for future track days or conditions.

Ride Height:

The standard starting point for ride height is 5.0mm (keep in mind that your local track may have minimum ride height requirements). You can slightly raise the rear relative to the front to give the car more steering. Raise the car slightly for tracks with large bumps.

Battery Placement:

For most cases, run the battery in the standard forward position. Typically this will be the most stable and easiest to drive. Try moving the battery back if you encounter a low traction surface.

Wheelbase:

Lengthening the front will reduce steering, shortening the front will increase steering. Shortening the rear will increase rear grip, lengthening the rear will decrease rear traction.

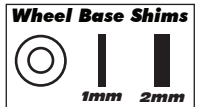

Rear Toe-In:

Decreasing toe-in will decrease rear traction and increase corner speed. Use numbered toe shims for adjustment.



Ackermann & Steering Rate:

Ackermann refers to the relative angle difference between the front wheels as they are turned to steer the car. The outside wheel will turn less than the inside wheel in most conditions. Settings with more Ackermann will have a bigger difference in wheel angle, causing the outside wheel to turn less. Likewise, settings with less Ackermann will cause the outside wheel to turn more.

Increasing the Ackermann will smooth out the steering and is used most often on high traction surfaces such as carpet. This is a result of the reduced outside wheel angle. Settings with reduced Ackermann will help to increase corner entry steering, and are typically used when running a spool in the front.

The steering rate is also adjusted when changing the length of the steering bellcrank. There are three rate options. The shortest position (position C) produces a slower speed than the longest position (position A). Slower steering rates will make the car less aggressive, making it easier to drive. These settings are good for high traction conditions such as carpet.

The chart to the right lists the different Ackermann options along with their associated steering rates.

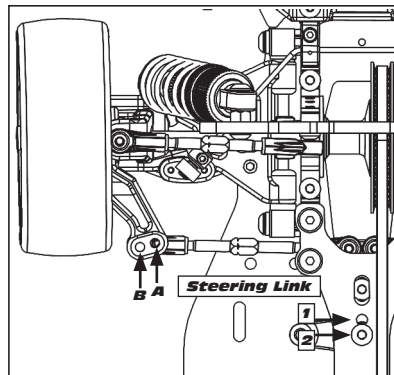
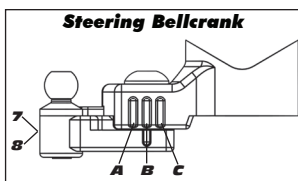

Steering Link	Steering Bellcrank	Steering Speed	
7A	2B	Fast	Less Ackermann ↑
8A	2B	Fast	
7C	1B	Slow	
8C	1B	Slow	
7B	2B	Medium	
8B	2B	Medium	
7A	2A	Fast	More Ackermann ↓
8A	2A	Fast	
7C	2B	Slow	
7C	1A	Slow	
8C	2B	Slow	
8C	1A	Slow	
7B	2A	Medium	
8B	2A	Medium	
7C	2A	Slow	
8C	2A	Slow	

:: Tuning Tips

Caster:

Caster describes the angle of the kingpin from vertical while looking from the side of the car. Positive caster means the top of the kingpin leans rearward. Negative caster means the kingpin is leaning towards the front of the car. Since caster is measured at the wheel, it is affected by running any inclination in your inboard arm mount. Kick-up adds (+) caster, and anti-dive adds (-) caster.

When figuring out your caster at the wheel, add the number of degrees of kick-up or anti-dive and add it to the degree caster blocks you have on the car.

Typically for most racing surfaces, 4 degrees caster is the normal starting point for the Team. From there, increase caster to reduce mid to exit steering and make the front end less responsive. Conversely, decreased caster gives a more responsive feel and more exit steering.

Droop:

The standard settings of 7mm front and 6mm rear will work best in most cases. Droop is measured just underneath the outer hinge pin as shown in the photos to the right.

On bumpy or low grip surfaces, increase the droop (going to a lower number on the droop gauge), this will help increase traction and consistency.

Droop adjustments of 0.5mm to 1mm can be very effective on the track!

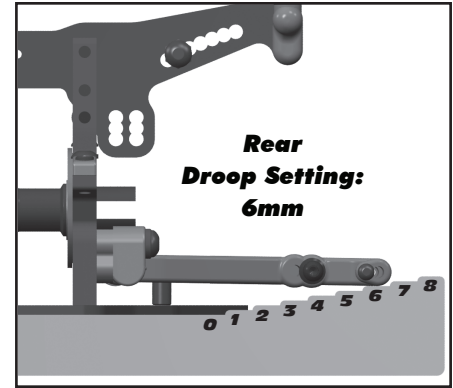
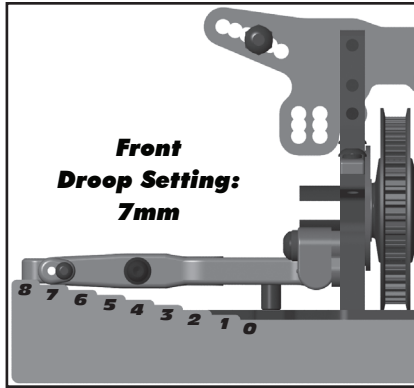

Camber Link Position:

The camber link is used to set static camber at ride height, but it is also an effective setting to adjust roll center height and camber gain. The TC6 has 7 positions for the front camber link, and 14 for the rear. These positions vary in both length and angle.

Longer links will produce less camber gain, stiffening that particular end of the car in roll. These are particularly effective on large tracks with big sweeping corners. Shorter links will give more camber gain, softening that end of the car in roll. This will make the car more aggressive, and is a good setting for smaller indoor tracks with high grip levels.

The angle of the camber link will make fine adjustments to the roll center height. Typically the camber link will be no more than parallel to the suspension arm with the inboard side of the link lower than the outboard side. As the inboard side of the camber link is moved down, the roll center goes up, stiffening that end of the car. Camber link angle is a good adjustment to help fine tune the balance of the car to the track by setting the front and rear at slightly different angles.

Arm Mount Position:

The TC6's arm mounting system allows for maximum adjustability for all track and racing conditions. Six arm mount positions allow you to run the pins flat, or with angle to produce kick-up, anti-dive, anti-squat, and pro-squat. The arm mounts are indicated zero, one, two, and three, with the corresponding number of dots on the outer face. Zero is the lower roll center and three the higher roll center, with one and two in order between.

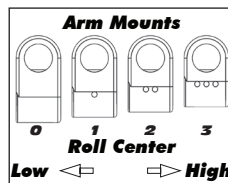

Each bulkhead has two positions to attach the arm mount to. The lower position (A) is used for the lowest roll center options, and the upper position (B) is used for the highest roll center options.

In general, lower roll centers will effectively make the car softer in roll, allowing the car to lean more in the corners. Lower roll center positions are good for low traction conditions. If the grip level is high, then raising the roll centers to a higher position will help to stiffen the car in roll making it more stable.

The following chart shows some examples of arm mounting positions along with their resulting arm angles shown in degrees.

	Fwd Mount	Rwd Mount	Result	Roll Center		Fwd Mount	Rwd Mount	Result	Roll Center
Front	3B	3B	Flat	↑ High ↓ Low	↑ High ↓ Low	3B	3B	Flat	↑ High ↓ Low
	3B	2B	1° Kick Up			3B	2B	1° Anti Squat	
	2B	3B	1° Anti Dive			2B	3B	1° Pro-Squat	
	3B	1B	2° Kick Up			3B	1B	2° Anti Squat	
	1B	3B	2° Anti Dive			1B	3B	2° Pro-Squat	
	2B	2B	Flat (std)			2B	2B	Flat	
	2B	1B	1° Kick Up			2B	1B	1° Anti Squat	
	1B	2B	1° Anti Dive			1B	2B	1° Pro-Squat	
	2B	0B	2° Kick Up			2B	0B	2° Anti Squat	
	0B	2B	2° Anti Dive			0B	2B	2° Pro-Squat	
	1B	1B	Flat			1B	1B	Flat	
	1B	0B	1° Kick Up			1B	0B	1° Anti Squat	
	0B	1B	1° Anti Dive			0B	1B	1° Pro-Squat	
	0B	0B	Flat			0B	0B	Flat	

:: Tuning Tips

Kick-Up (front):

Kick-up describes the angle of the front suspension arm, where the front mount is higher than the rear mount. Increasing kick-up will give more entry steering, as well as increasing caster at the wheel.

Anti-Dive (front):

Anti-dive is a front arm angle where the rear mount is higher than the front mount. Adding anti-dive reduces weight transfer to the front on deceleration entering corners. It also reduces caster at the wheel.

Anti-Squat (rear):

Anti-Squat describes a rear arm angle where the front mount is higher than the rear mount. Increasing anti-squat will make the rear suspension stiffer. It tends to give the car more entry steering and reduce rearward weight transfer on power.

Pro-Squat (rear):

Pro-squat is a rear arm angle where the rear mount is higher than the front mount. Running Pro-Squat will increase rearward weight transfer on power.

Belt Tension:

When altering the differential height, you will need to adjust the tension of the belt. The following chart shows suggested starting positions.

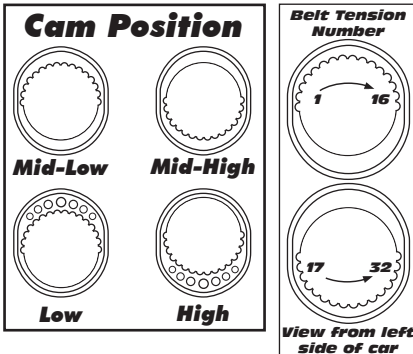

Front	Height	Pos.
	High	31
	Mid-High	28
	Mid	9
Low	6	

Rear	Height	Pos.
	High	18
	Mid-High	20
	Mid	6
Low	8	

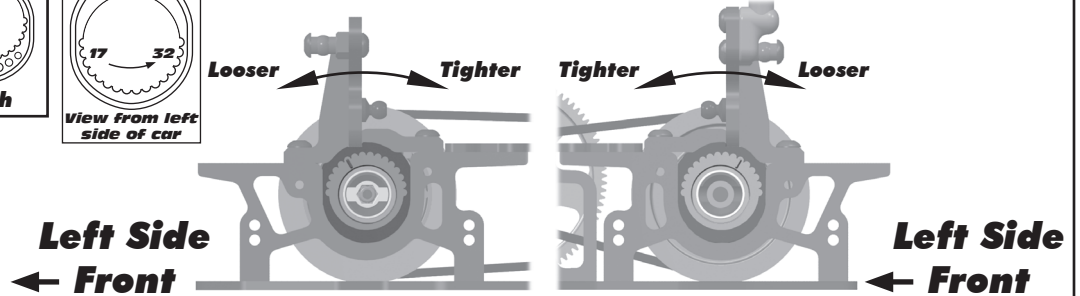

Note! Charts show left side cam positions from the left side of the car. Match right side cam position to left side cam position.

Motor Gearing:

The following chart shows final drive ratio numbers for the TC6. Refer to motor manufacturer's suggested gear ratio for starting point. You may need to adjust the gearing according to your track size.

The following formula's can be helpful in determining final drive ratios and pinion size.

$$TC6 \text{ Internal Ratio} = 2.0$$

$$\text{Final Drive Ratio} = \frac{\# \text{ of Teeth Spur} \times \text{Internal Ratio}}{\# \text{ of Teeth on Pinion}}$$

$$\# \text{ of Teeth on Pinion} = \frac{\# \text{ of Teeth on Spur} \times \text{Internal Ratio}}{\text{Final Drive Ratio}}$$

Spur Gear Teeth (48 Pitch)

	80	81	82	83	84	85	86	87
17	9.41	9.53	9.65	9.76	9.88	10.00	10.12	10.24
18	8.89	9.00	9.11	9.22	9.33	9.44	9.56	9.67
19	8.42	8.53	8.63	8.74	8.84	8.95	9.05	9.16
20	8.00	8.10	8.20	8.30	8.40	8.50	8.60	8.70
21	7.62	7.71	7.81	7.90	8.00	8.10	8.19	8.29
22	7.27	7.36	7.45	7.55	7.64	7.73	7.82	7.91
23	6.96	7.04	7.13	7.22	7.30	7.39	7.48	7.57
24	6.67	6.75	6.83	6.92	7.00	7.08	7.17	7.25
25	6.40	6.48	6.56	6.64	6.72	6.80	6.88	6.96
26	6.15	6.23	6.31	6.38	6.46	6.54	6.62	6.69
27	5.93	6.00	6.07	6.15	6.22	6.30	6.37	6.44
28	5.71	5.79	5.86	5.93	6.00	6.07	6.14	6.21
29	5.52	5.59	5.66	5.72	5.79	5.86	5.93	6.00
30	5.33	5.40	5.47	5.53	5.60	5.67	5.73	5.80
31	5.16	5.23	5.29	5.35	5.42	5.48	5.55	5.61
32	5.00	5.06	5.13	5.19	5.25	5.31	5.38	5.44
33	4.85	4.91	4.97	5.03	5.09	5.15	5.21	5.27
34	4.71	4.76	4.82	4.88	4.94	5.00	5.06	5.12

:: Shocks

5407	Red O-Rings	8
6465	Shock Piston, PTFE	12
6475	Preload Spacers, Collars, Cups	1
31249	Shock Shaft Ball Cup	4
31323	VCS3 Shock Kit	1
31324	VCS3 Shock Rebuild	1
31325	VCS3 Shock Body	2
31326	VCS3 Shock Collar	2
31327	VCS3 Shock Bottom Cap	2
31328	VCS3 Aluminum Cap Retainer	2
31329	VCS3 Shock Cap	4
31330	VCS3 Shock Shaft	2
31510	M2x4mm BHCS	6

:: Springs

3941	TC Spring, Green, 12.0lbs (Kit)	Pr.
3942	TC Spring, Silver, 14.5lbs (Kit)	Pr.
3943	TC Spring, Blue, 17.0lbs	Pr.
3944	TC Spring, Gold, 19.5lbs	Pr.
3945	TC Spring, Red, 22.0lbs	Pr.
3946	TC Spring, Copper, 25.0lbs	Pr.
3952	TC Spring, Purple, 30.0lbs	Pr.
3953	TC Spring, Yellow, 35.0lbs	Pr.
3954	TC Spring, White, 40.0lbs	Pr.
3988	TC Spring Set, 1 pr. each	1

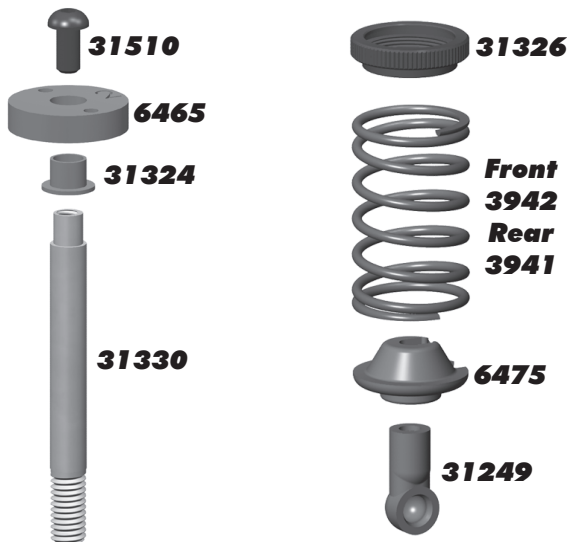

:: Shock Oil

5420	10 Weight Silicone Shock Oil	2oz.
5421	20 Weight Silicone Shock Oil	2oz.
5422	30 Weight Silicone Shock Oil	2oz.
5423	40 Weight Silicone Shock Oil	2oz.
5425	80 Weight Silicone Shock Oil	2oz.
5427	15 Weight Silicone Shock Oil	2oz.
5428	25 Weight Silicone Shock Oil	2oz.
5429	35 Weight Silicone Shock Oil	2oz.
5430	45 Weight Silicone Shock Oil	2oz.
5431	55 Weight Silicone Shock Oil	2oz.
5435	50 Weight Silicone Shock Oil	2oz.
5436	60 Weight Silicone Shock Oil	2oz.
5437	70 Weight Silicone Shock Oil	2oz.



:: CVA's

31226	CVA Kit	1
31227	CVA Rebuild Kit	1
31231	Stub Axle	Pr.
31232	CVA Bone	Pr.
31237	CVA Pin Retaining Clip	2
31238	CVA Bone Blade	8
31500	M3x2.5mm Set Screw	6

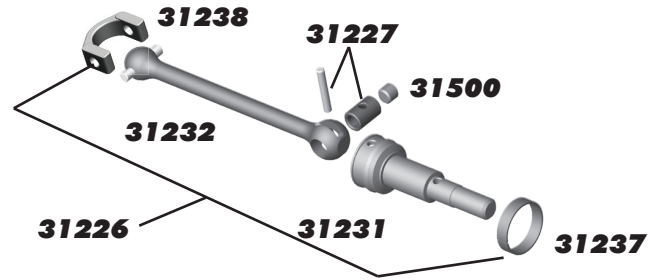

:: Anti-Roll Bars

8828	Anti-Roll Bar Cups, Set	1
31058	Anti-Roll Bar Ballstud, blue aluminum	2
31261	1.25mm Anti-Roll Bar, black	2
31262	1.5mm Anti-Roll Bar, silver	2
31263	1.75mm Anti-Roll Bar, gold	2
31264	Anti-Roll Bar Mounts, Set	1
31269	Anti-Roll Bar Kit	1
31500	M3x2.5mm Set Screw	6
31511	M2x5mm SHCS	6

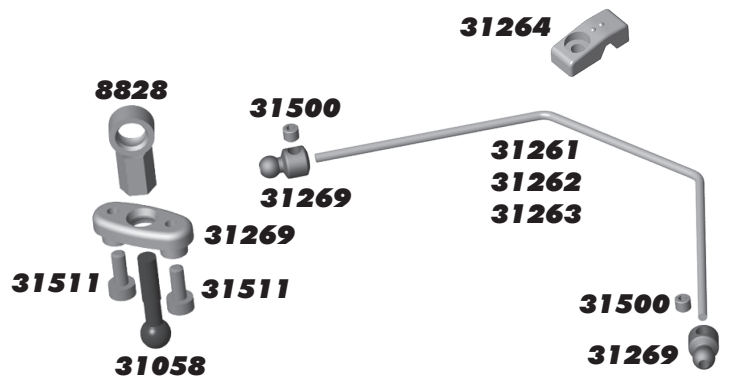

:: Turnbuckles

1402	FT Blue Titanium Turnbuckles 1.375"	Pr.
1403	FT Blue Titanium Turnbuckle 1.65"	Pr.
1405	FT Blue Titanium Turnbuckle 1.875"	Pr.
1418	FT Blue Titanium Turnbuckle 0.825"	Pr.
31305	Turnbuckle Eyelet	14

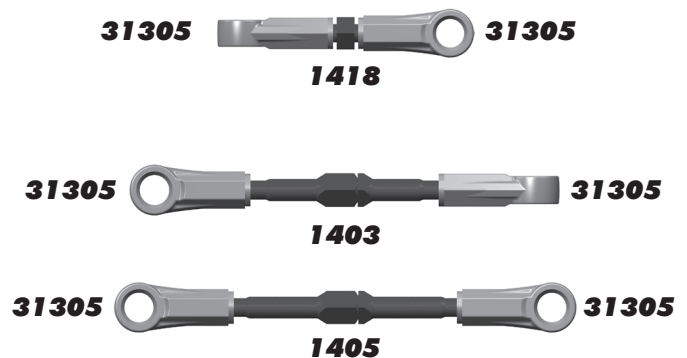

:: Front Slipper Spool

3904	2-56 Mini Lock Nut	4
6573	Diff Thrust Washers & Bolt	2
6574	5/64" Diff Thrust Balls	6
6582	Diff Thrust Spring	1
31162	Axle Shim Kit	1
31166	Diff Rebuild Kit	1
31169	Diff Pulley - 40T	1
31173	Slipper Spool Pads	Pr.
31184	Cam Holder Set	1
31185	Diff Bearing Cam	2
31337	TC6 Slipper Spool Kit	1
31338	TC6 Diff Outdrives	Pr.
31400	5x8mm Bearing	2
31401	10x15mm Bearing	2

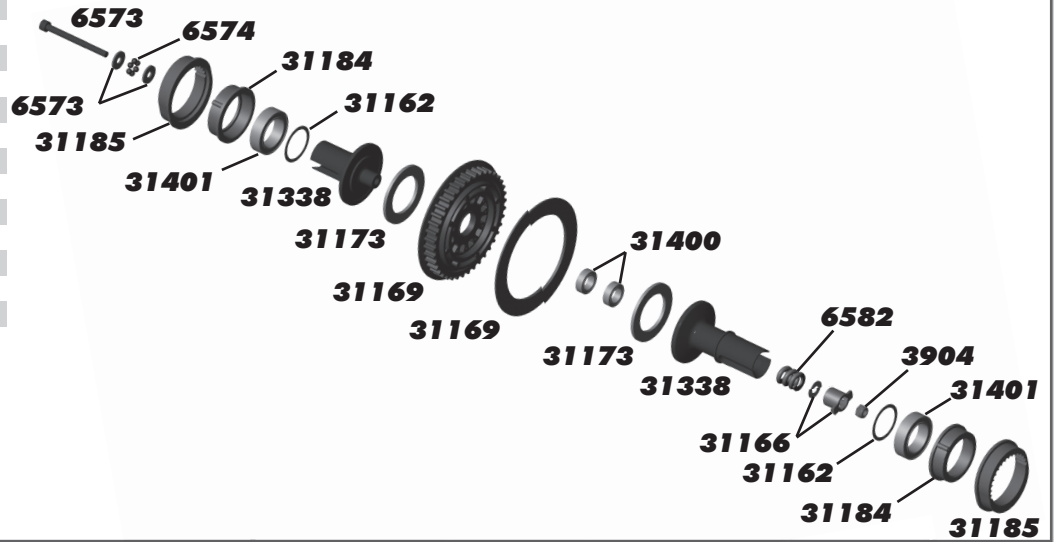

:: Rear Differential

3904	2-56 Mini Lock Nut	4
3906	D-Drive Rings	Pr.
6573	Diff Thrust Washers & Bolt	2
6574	5/64" Diff Thrust Balls	6
6581	3/32" Carbide Diff Balls	12
6582	Diff Thrust Spring	1
31162	Axle Shim Kit	1
31166	Diff Rebuild Kit	1
31169	Diff Pulley - 40T	1
31184	Cam Holder Set	1
31185	Diff Bearing Cam	2
31336	TC6 Differential Kit	1
31338	TC6 Diff Outdrives	Pr.
31400	5x8mm Bearing	2
31401	10x15mm Bearing	2

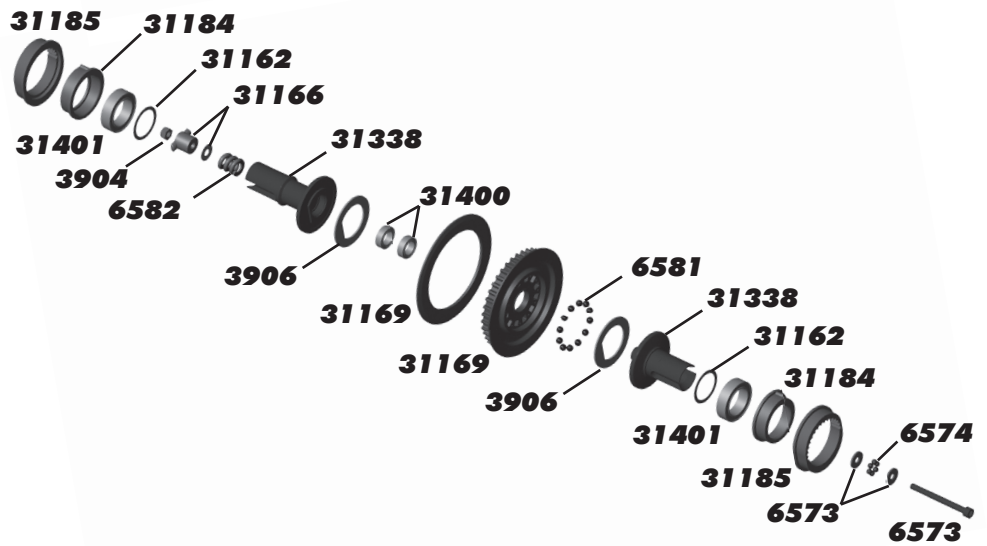

:: Spur Gear Assembly

31160	3mm E-Clip	6
31314	TC6 Spur Gear Hub	1
31315	TC6 Spur Gear Shaft	1
31319	TC6 Spur Clamping Ring	1
31320	TC6 Spur Pulley (20T)	2
31331	4x8x3mm Flanged Bearing	2
31333	TC6 Spur Gear (87T/48P)	1
31521	M2.5x0.5x8mm BHCS	6
31530	M3x0.5x5mm BHCS	6

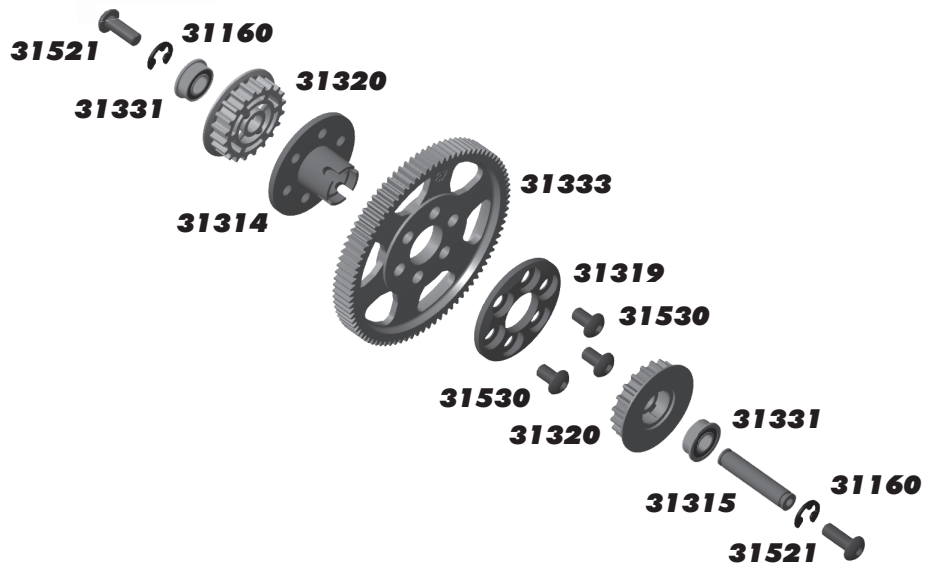

:: Steering Bellcrank and Servo Mounts

7336	Steering Servo Mount Kit	1
7337	.250" x.125" x.015" Washer	4
9180	Servo Horns, Molded	1
31246	Servo Mounts	Pr.
31280	5mm Ballstud, short	6
31286	Aluminum Ballstud Washers, Set	1
31306	TC6 Servo Saver Tube Assembly	1
31307	TC6 Steering Post	1
31308	TC6 Bellcrank Assembly	1
31403	4x7mm Bearing	2
31530	M3x5mm BHCS	6
31532	M3x8mm BHCS	6
31540	M3x5mm FHCS	6
89007	Steering Servo Horn (Ring)	1



:: Front Bumper

1736	FT Body Clips, short	6
2230	F/R Body Mounts, Set	1
3897	Pivoting Body Mounts, Set	1
4673	M2.5x4mm BHCS	6
25201	M3x8mm FHCS	20
25202	M3x10mm FHCS	20
25203	M3x12mm FHCS	20
31316	TC6 Bumper and Brace	1
31317	TC6 Foam Bumper	1
31530	M3x5mm BHCS	6

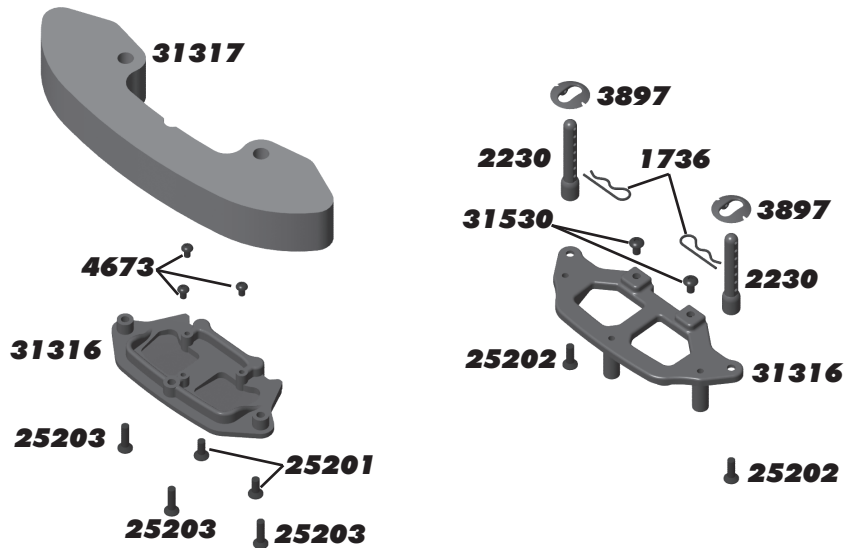

:: Front and Rear Shock Towers

1736	FT Body Clips, short	6
2230	F/R Body Mounts, Set	1
3897	Pivoting Body Mounts, Set	1
31250	Shock Bushing	4
31281	8mm Ballstud, short	6
31302	TC6 Shock Tower, Front	1
31303	TC6 Shock Tower, Rear	1
31310	TC6 Bearing Cap	1
31530	M3x5mm BHCS	6
31531	M3x6mm BHCS	6
31532	M3x8mm BHCS	6
31541	M3x6mm FHCS	6

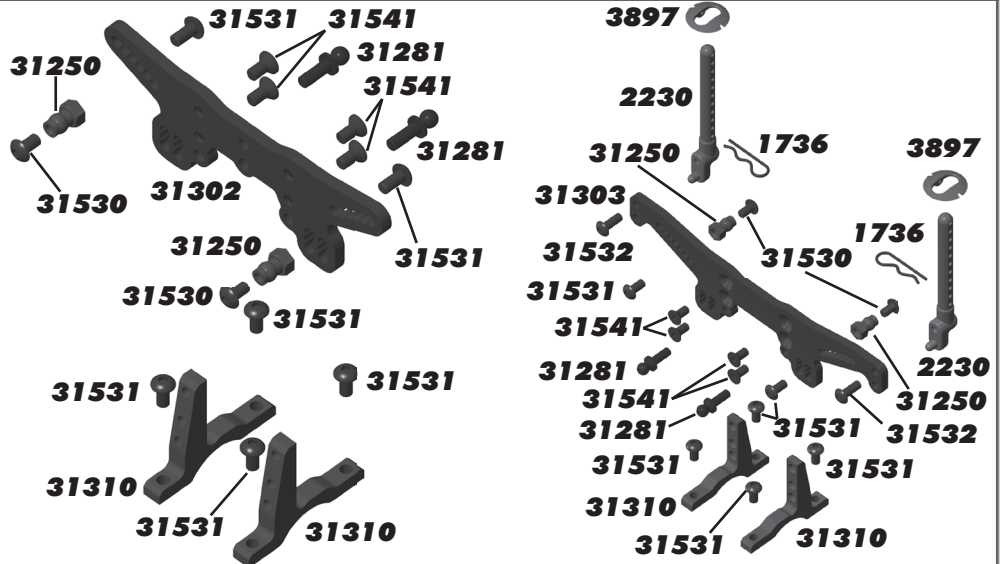

:: Front Bulkhead

25187	M3x14mm BHCS	20
25227	M4x8mm Setscrew	20
31112	1/16" x 5/16" Dowel Pins	8
31162	Axle Shim Kit	1
31198	Arm Mount Shim Set	1
31200	Wheelbase Shim Set	1
31203	Front Suspension Arm (HARD)	Pr.
31205	Front Suspension Arm	Pr.
31210	Caster Block (0 deg)	Pr.
31211	Caster Block (2 deg)	Pr.
31212	Caster Block (4 deg)	Pr.
31213	Caster Block (6 deg)	Pr.
31214	Caster Block Bushing	Pr.
31215	Steering Block Set	1
31221	Inner Hinge Pin Set	1
31222	Outer Hinge Pin Set	1
31233	Axle Crush Tube	4
31234	Clamping Wheel Hex	4
31264	Anti-Roll Bar Mounts, Set	1
31280	5mm Ballstud, short	6
31281	8mm Ballstud, short	6
31286	Aluminum Ballstud Washers, Set	1
31309	TC6 Bulkhead	1
31321	TC6 Arm Mount Set	1
31322	TC6 Arm Mount Bushing	8
31404	6x10mm Bearing	2
31510	M2x4mm BHCS	6
31511	M2x5mm SHCS	6
31532	M3x8mm BHCS	6
31540	M3x5mm FHCS	6
31555	Caster Block 0 deg (HARD)	Pr.
31556	Caster Block 2 deg (HARD)	Pr.
31557	Caster Block 4 deg (HARD)	Pr.
31558	Caster Block 6 deg (HARD)	Pr.
31561	Steering Block (HARD)	Pr.
89216	M4 Locknut	10

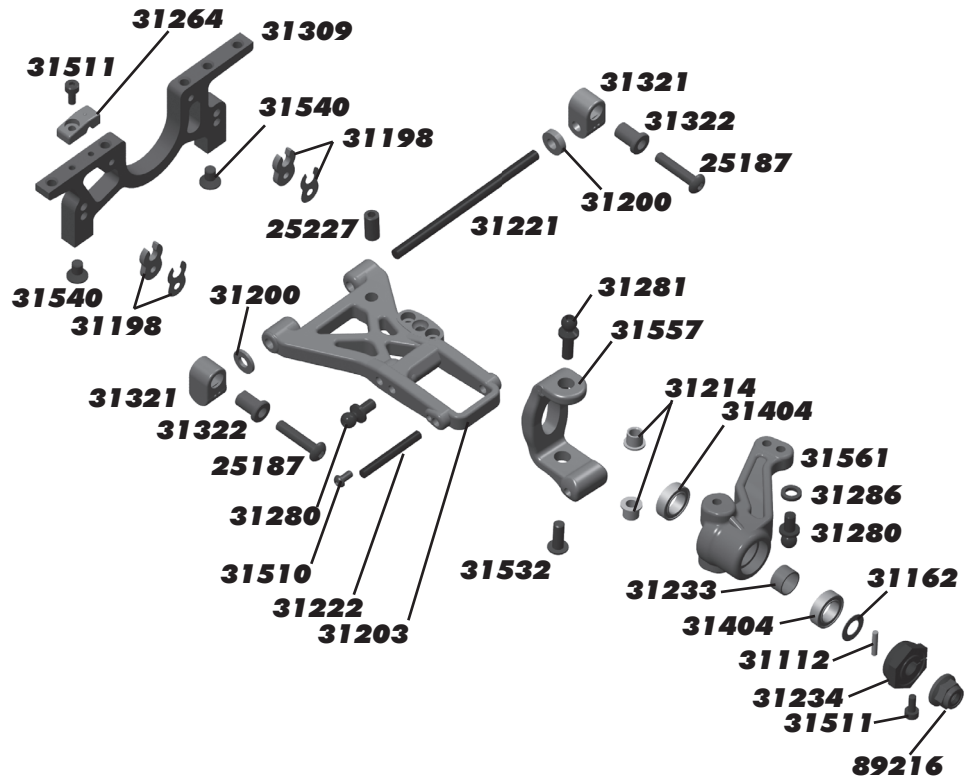

:: Rear Bulkhead

25187	M3x14mm BHCS	20
25227	M4x8mm Setscrew	20
31112	1/16" x 5/16" Dowel Pins	8
31162	Axle Shim Kit	1
31198	Arm Mount Shim Set	1
31200	Wheelbase Shim Set	1
31204	Rear Suspension Arm (HARD)	Pr.
31206	Rear Suspension Arm	Pr.
31218	Rear Hub (0 deg)	Pr.
31219	Rear Hub (0.5 deg)	Pr.
31220	Rear Hub (1 deg)	Pr.
31221	Inner Hinge Pin Set	1
31222	Outer Hinge Pin Set	1
31233	Axle Crush Tube	4
31234	Clamping Wheel Hex	4
31264	Anti-Roll Bar Mounts, Set	1
31280	5mm Ballstud, short	6
31281	8mm Ballstud, short	6
31286	Aluminum Ballstud Washers, Set	1
31309	TC6 Bulkhead	1
31321	TC6 Arm Mount Set	1
31322	TC6 Arm Mount Bushing	8
31404	6x10mm Bearing	2
31510	M2x4mm BHCS	6
31511	M2x5mm SHCS	6
31540	M3x5mm FHCS	6
31562	Rear Hub 0 deg (HARD)	Pr.
31563	Rear Hub 0.5 deg (HARD)	Pr.
31564	Rear Hub 1 deg (HARD)	Pr.
89216	M4 Locknut	10

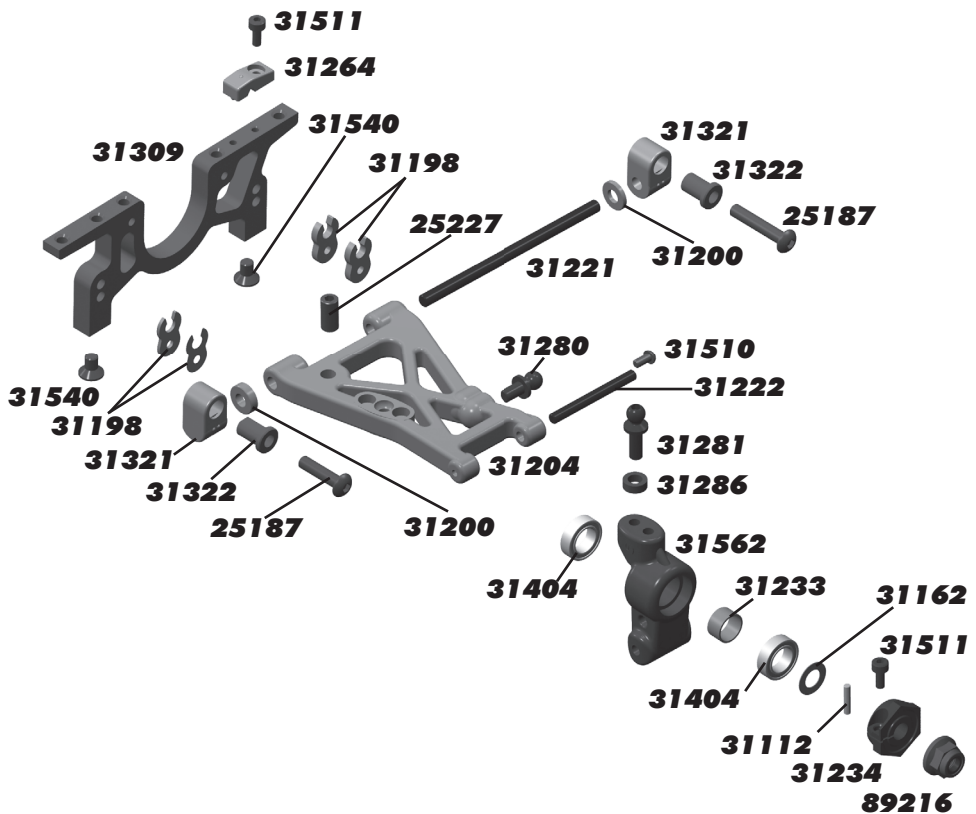

:: Chassis / Top Plate / Belts / Antenna / Battery Braces / Motor Mount

6338	Antenna Tube 12", black	1
31187	Front Belt	1
31188	Rear Belt	1
31286	Aluminum Ballstud Washers, Set	1
31300	TC6 Chassis	1
31301	TC6 Top Plate	1
31304	TC6 Battery Tape Tab	Pr.
31311	TC6 Spur Gear Bulkhead	Pr.
31312	TC6 Motor Mount	1
31313	TC6 Motor Mount Brace	1
31318	TC6 Battery Brace Set	1
31500	M3x2.5mm Set Screw	6
31530	M3x5mm BHCS	6
31531	M3x6mm BHCS	6
31532	M3x8mm BHCS	6
31540	M3x5mm FHCS	6
31541	M3x6mm FHCS	6

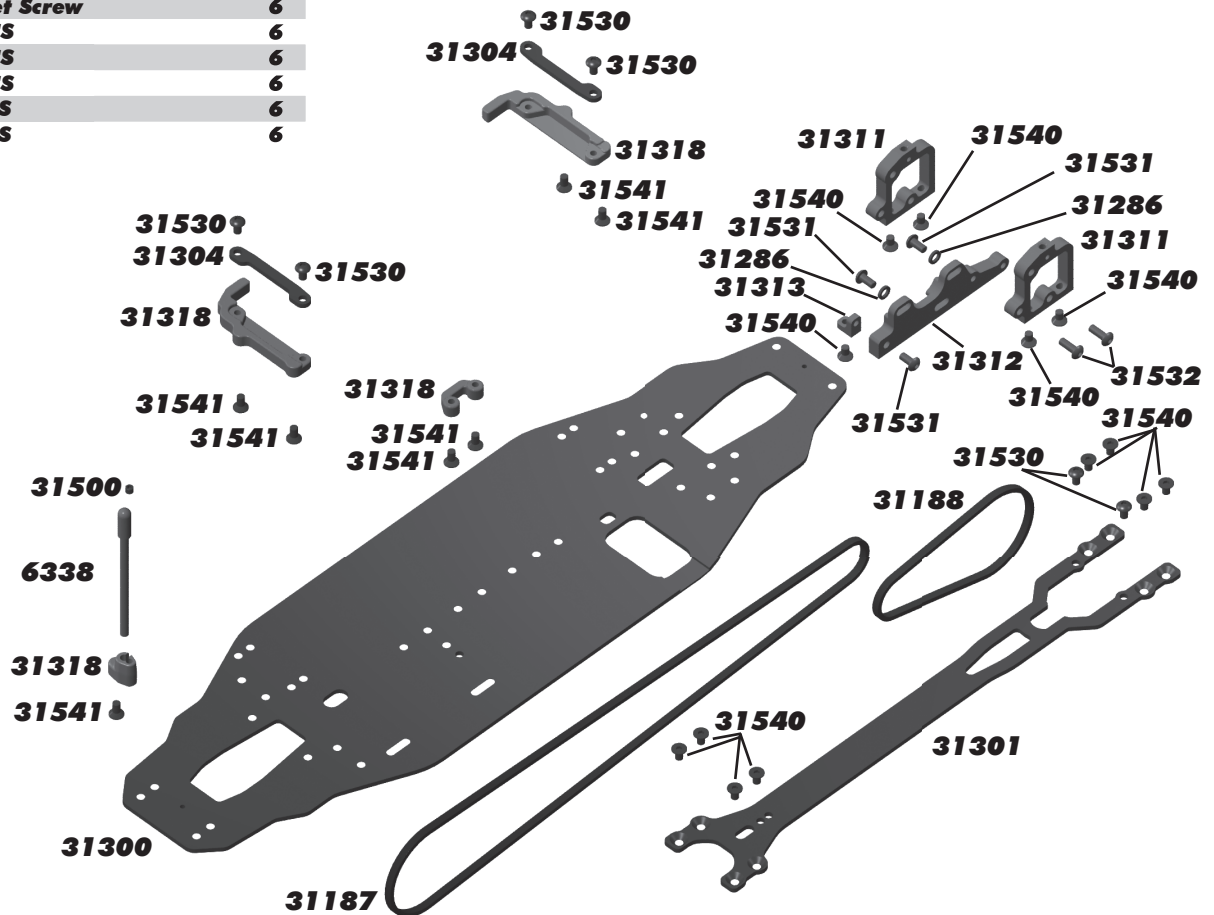

:: Lubes & Adhesives / Decals / Misc.

1105	FT Green Slime Shock Lube	1
1596	FT Locking Adhesive	1
1597	FT Tire Adhesive, medium	1
6588	Black Grease - 4cc	1
6591	S.Diff Lube - 4cc	1
6636	Silicone Grease - 4cc	1
6727	Servo Tape	2
716	Reedy 2009 Sticker Set	1
717	Reedy Powered Logo Decal	1
3816	American Bumper Sticker	1
3820	AE Logo Decal Sheet	1
3834	AE Blue Embossed Logo Sticker	2
31299	TC6 Decal Sheet	1



:: Pinions / Spur Gears

8253	16T 48P Pinion Gear	1	3921	69T 48P Spur Gear	1
8254	17T 48P Pinion Gear	1	3922	72T 48P Spur Gear	1
8255	18T 48P Pinion Gear	1	3923	75T 48P Spur Gear	1
8256	19T 48P Pinion Gear	1	3992	76T 48P Spur Gear	1
8257	20T 48P Pinion Gear	1	3993	77T 48P Spur Gear	1
8258	21T 48P Pinion Gear	1	3994	73T 48P Spur Gear	1
8259	22T 48P Pinion Gear	1	3995	74T 48P Spur Gear	1
8260	23T 48P Pinion Gear	1	4462	100T 64P Spur Gear	1
8261	24T 48P Pinion Gear	1	4615	96T 64P Spur Gear	1
8262	25T 48P Pinion Gear	1	31332	80T 48P Spur Gear	1
8263	26T 48P Pinion Gear	1	31333	87T 48P Spur Gear	1
8264	27T 48P Pinion Gear	1	31334	106T 64P Spur Gear	1
8265	28T 48P Pinion Gear	1	31335	115T 64P Spur Gear	1
8266	29T 48P Pinion Gear	1			
8267	30T 48P Pinion Gear	1			
8268	31T 48P Pinion Gear	1			
8269	32T 48P Pinion Gear	1			
8270	33T 48P Pinion Gear	1			
8271	34T 48P Pinion Gear	1			
8272	35T 48P Pinion Gear	1			

:: Factory Team and Option Parts

1401	1.300" Ti Turnbuckles	2
1402	1.375" Ti Turnbuckles	2
1734	FT Blue Body Clip, 4 long, 6 short	10
1735	FT Blue Body Clip, long	4
1736	FT Blue Body Clip, short	6
3927	Radial Heatsink, narrow	1
3928	Radial Heatsink, wide	1
3991	TC Aero Dish Wheel 24mm	4
6860	FT 4-40x3/8" SHCS, blue aluminum	6
6934	FT 4-40x3/8" FHCS, blue aluminum	6
6937	FT 4-40 Lock Nuts, blue	6
6939	FT 4-40x1/4" FHCS, blue aluminum	6
6943	FT 8-32 Lock Nuts, blue	6
6946	FT 4-40x5/16" BHCS, blue aluminum	6
6947	FT 4-40x3/8" BHCS, blue aluminum	6
7869	FT 4-40x3/4" FHCS, blue aluminum	8
7873	FT 4-40x7/16" SHCS, blue aluminum	6
25391	FT 4mm Locknuts, blue	10
31286	Aluminum Ballstud Washer, Set	1
31288	Ti Nitride Ballstuds M3x5mm, short	2
31289	Ti Nitride Ballstuds M3x8mm, short	2
31290	Ti Nitride Ballstuds M3x10mm, short	2
31291	Ti Nitride Ballstuds M3x5mm, long	2
31292	Ti Nitride Ballstuds M3x8mm, long	2
31293	Ti Nitride Ballstuds M3x10mm, long	2
31296	TC6 Ballast Weight	1
31339	TC6 Spool Kit	1
31550	M3 Aluminum Lock Nut	6
31551	M4 Aluminum Flange Lock Nut	6

:: XP Electronics

29125	S1903MG Servo	1
29126	S2008MG Servo	1
29140	XP SC200 Brushed ESC	1
29141	XP SC450-BL Brushless ESC	1
29166	XP DS1313 Digital Servo	1
29167	XP DS1015 Digital Servo	1
29209	Gear Set, DS1313	1
29210	Gear Set, DS1015	1
29211	Servo Case, DS1313/DS1015	1
29212	Accessory Pack, DS1313/DS1015	1
29221	XP3SS 2.4GHz Radio System	1
29222	TRS401SS 2.4GHz 4Ch Receiver	1

:: Reedy Motors and ESC's

300	Stockstar 27-turn ROAR Stock	1
410	Flash 12-turn	1
411	Flash 13-turn	1
412	Flash 14-turn	1
413	Flash 15-turn	1
414	Flash 17-turn	1
415	Flash 19-turn	1
416	Flash 55-turn	1
517	Challenger 19-turn ROAR Spec	1
916	540R Brushless Motor 3300kV	1
917	540R Brushless Motor 3900kV	1
918	540R Brushless Motor 4900kV	1
919	540R Brushless Motor 6100kV	1
936	XP SC450-BL/Reedy 540R 3300kV Combo	1
937	XP SC450-BL/Reedy 540R 3900kV Combo	1
938	XP SC450-BL/Reedy 540R 4900kV Combo	1
939	XP SC450-BL/Reedy 540R 6100kV Combo	1
9626	Radon 17T 30,000 RPM	1

:: Reedy Batteries

302	AA Alkaline 1.5V (4)	1
303	AA 2700mAh NiMH 1.2V Rechargeable (4)	1
626	LiPo 60C 5500mAh 14.8V	1
627	LiPo 60C 5200mAh 7.4V SP	1
628	LiPo 60C 5500mAh 7.4V	1
629	LiPo 60C 5500mAh 3.7V	1
632	TX Lightweight Battery 1350mAh 11.1V	1
633	TX Battery - 3PK, M11 3000mAh 11.1V	1
634	TX Battery - Helios, Z1 2400mAh 11.1V	1
637	TX Battery - M11X 2500mAh 7.4V	1
681	Wolfpack 2400mAh 7.2V w/DEANS® connector	1
682	Wolfpack 3000mAh 7.2V w/DEANS® connector	1
683	Wolfpack 3600mAh 7.2V w/DEANS® connector	1
684	Wolfpack 4200mAh 7.2V w/DEANS® connector	1
685	LiPo 40C+ 5000mAh 7.4V	1
686	LiPo 40C+ 4200mAh 7.4V SP	1
689	R-Power 1700mAh 7.2V w/TAM connector	1
693	Wolfpack 2400mAh 7.2V w/TAM connector	1
694	Wolfpack 3000mAh 7.2V w/TAM connector	1
695	Wolfpack 3600mAh 7.2V w/TAM connector	1
696	Wolfpack 2400mAh 7.2V w/TRA connector	1
697	Wolfpack 3000mAh 7.2V w/TRA connector	1
698	Wolfpack 3600mAh 7.2V w/TRA connector	1
700	Wolfpack 4200mAh 7.2V w/TAM connector	1
703	LiPo 5000mAh Pro 7.4V 20C	1
704	LiPo 5000mAh 7.4V 20Cw/TAM connector	1
709	LiPo 5000mAh 7.4V 35C ROAR Spec	1
710	LiPo 5100mAh 7.4V 35C SP ROAR Spec	1
711	LiPo 4900mAh 7.4V 35C EFRA Spec	1
712	LiPo 4200mAh 7.4V 35C SP EFRA Spec	1
713	LiPo 2400mAh 7.4V 20C Stick	1
714	LiPo 3400mAh 7.4V 25C Stick	1
723	LiFe 4000mAh 6.6V 30C	1

:: Reedy Accessories

605	Motor Cooling Fans (2)	1
651	Battery Bars (8)	1
652	Battery Bars (30)	1
653	Battery Bars (100)	1
654	4.0mm plugs (2M, 2F)	1
655	4.0mm plugs (2M, 10F)	1
656	4.0mm plugs (10F)	1
657	4.0mm plugs (100F)	1
658	4.0mm plugs (10M)	1
659	4.0mm plugs (30M)	1
660	3.5mm plugs (3M, 3F)	1
661	3.5mm plugs (10F)	1
662	3.5mm plugs (100F)	1
663	3.5mm plugs (10M)	1
664	3.5mm plugs (30M)	1
665	Single Cell Shrink - Clear (12)	1
666	Single Cell Shrink - Clear (30)	1
667	Single Cell Shrink - Clear (100)	1
716	Reedy 09 Decal Set	1
SP35M	Reedy Logo T-Shirt - White M	1
SP35L	Reedy Logo T-Shirt - White L	1
SP35XL	Reedy Logo T-Shirt - White XL	1
SP35XXL	Reedy Logo T-Shirt - White XXL	1
SP35XXXL	Reedy Logo T-Shirt - White XXXL	1
SP36M	Reedy Logo T-Shirt - Black M	1
SP36L	Reedy Logo T-Shirt - Black L	1
SP36XL	Reedy Logo T-Shirt - Black XL	1
SP36XXL	Reedy Logo T-Shirt - Black XXL	1
SP36XXXL	Reedy Logo T-Shirt - Black XXXL	1
SP417	Factory Team 1/10 Motor Storage Bag	1
SP418	Factory Team 1/10 Car Carrier Bag	1

:: LRP Brushless Motors

LRP50642	LRP X-12 9.5 Turn	1
LRP50652	LRP X-12 8.5 Turn	1
LRP50662	LRP X-12 7.5 Turn	1
LRP50672	LRP X-12 6.5 Turn	1
LRP50682	LRP X-12 5.5 Turn	1
LRP50687	LRP X-12 5.0 Turn	1
LRP50692	LRP X-12 4.5 Turn	1
LRP50702	LRP X-12 4.0 Turn	1
LRP50712	LRP X-12 3.5 Turn	1
LRP50722	LRP X-12 3.0 Turn	1
LRP50832	Vector X-12 Stock-Spec 10.5 Turn	1
LRP50842	Vector X-12 Stock Spec 13.5 Turn	1
LRP50852	Vector X-12 Stock Spec 17.5 Turn	1
LRP50862	Vector X-12 Stock Spec 21.5 Turn	1

:: LRP Speed Controls

LRP8320	AI Super Reverse	1
LRP8325	AI Pro Reverse	1
LRP8337	AI Bullet Reverse	1
LRP80100	AI Brushless Reverse	1
LRP80150	AI Brushless Pro Reverse	1
LRP80400	SPX Brushless Super Reverse	1
LRP80800	V 8.1	1
LRP80915	SXX Stock-Spec Speed Control V.2	1
LRP86500	NEXXT 4X esc	1
LRP80905	SXX Competition V.2	1
LRP80955	SXX TC-Spec V.2	1
LRP80460	Ultimo Drift	1

:: LRP Brushless Combos

LRP80640	SXX TC / X-12 3.0 Turn	1
LRP80641	SXX TC / X-12 3.5 Turn	1
LRP80642	SXX TC / X-12 4.0 Turn	1
LRP80643	SXX TC / X-12 4.5 Turn	1
LRP80644	SXX TC / X-12 5.0 Turn	1
LRP80645	SXX TC / X-12 5.5 Turn	1
LRP80646	SXX TC / X-12 6.5 Turn	1
LRP80647	SXX TC / X-12 7.5 Turn	1
LRP80648	SXX TC / X-12 8.5 Turn	1
LRP80649	SXX TC / X-12 9.5 Turn	1
LRP80654	SXX COMP / X-12 5.0 Turn	1
LRP80655	SXX COMP / X-12 5.5 Turn	1
LRP80656	SXX COMP / X-12 6.5 Turn	1
LRP80657	SXX COMP / X-12 7.5 Turn	1
LRP80658	SXX COMP / X-12 8.5 Turn	1
LRP80659	SXX COMP / X-12 9.5 Turn	1
LRP80673	SXX Stock-Spec / X-12 Stock-Spec 10.5 Turn	1
LRP80674	SXX Stock-Spec / X-12 Stock-Spec 13.5 Turn	1
LRP80675	SXX Stock-Spec / X-12 Stock-Spec 17.5 Turn	1

:: LRP Charger, Power Supply, Balancer, Iron

LRP41281	Quadra Pro 2 Charger	1
LRP41555	Pulsar Touch Competition Charger	1
LRP43150	Power Supply Competition	1
LRP45200	LiPo Parallel Balancer	1
LRP65800	High Power Solder Station	1
LRP65802	Soldering Tip 5mm	1
LRP65803	Soldering Tip 1.2mm	1
LRP65804	Soldering Handle	1

:: LRP Misc.

LRP50620	X-12 Replacement Ball Bearings	1
LRP50621	X-12 Optional Ceramic Ball Bearings	1
LRP50622	X-12 Small parts Set	1
LRP50623	X-12 PreciSensor Unit	1
LRP50624	X-12 Replacement alum Front can	1
LRP50625	X-12 Lightweight Alum Can	1
LRP50626	X-12 Alum Rear Cover	1
LRP50632	X-12 12.0mm sintered rotor	1
LRP50633	X-12 12.5mm sintered rotor	1
LRP50634	X-12 13.0mm sintered rotor	1
LRP80135	BEC stabilizing capacitor	1
LRP82520	Brushless/Brushed Cooling Set	1
LRP82511	Brushless Low Profile Fan	1
LRP819307	70mm High Flex Sensor Wire	1
LRP819310	100mm High Flex Sensor Wire	1
LRP819315	150mm High Flex Sensor Wire	1
LRP819320	200mm High Flex Sensor Wire	1

:: Apparel

SP35**	Reedy 09' White T-Shirt (M, L, XL, XXL, XXXL)	1
SP36**	Reedy 09' Black T-Shirt (M, L, XL, XXL, XXXL)	1
SP58**	AE Logo Black T-Shirt (M, L, XL, XXL)	1
SP59**	AE Logo Blue T-Shirt (M, L, XL, XXL)	1
SP60**	AE Hooded Sweatshirt (S, M, L, XL, XXL)	1
SP61**	AE Vertigo Hooded Sweatshirt (S, M, L, XL, XXL)	1
SP62**	AE Vertigo Long Sleeve T-Shirt (S, M, L, XL, XXL)	1
SP63**	AE Vertigo White T-Shirt (S, M, L, XL, XXL)	1
SP64**	AE Vertigo Blue T-Shirt (S, M, L, XL, XXL)	1
SP65**	AE Vertigo Black T-Shirt (S, M, L, XL, XXL)	1
SP100	1/8 Inner and Outer Boxes Only, Set	1
SP101	1/8 Inner Boxes Only, Set	1
SP102	1/10 Inner and Outer Boxes Only, Set	1
SP103	1/10 Inner Boxes Only, Set	1
SP410**	AE Hats Black (S-M, L-XL, XXL-XXXL)	1
SP415	1/8 Car Carrier Bag Only	1
SP416	1/10 Car Carrier Bag Only	1
SP417	1/10 FT Motor Bag	1
SP418	1/10 FT Car Carrier Bag with Boxes, Set	1
SP420**	AE Pit Gloves (M, L, XL)	Pr.
715	Reedy 2009 Track Banner	1
110684	Team Associated Track Banner	1

** Use part number plus the desired size when ordering!

:: 1/18 Kits and RTR's

20100	RC18T RTR (ready-to-run)	1
20101	RC18T2 2.4ghz RTR (ready-to-run)	1
20103	RC18B2 - RC18T2 Team Kit	1
20104	RC18T2 Brushless RTR (ready-to-run)	1
20105	RC18B RTR (ready-to-run)	1
20106	RC18B2 2.4ghz RTR (ready-to-run)	1
20108	RC18B2 Brushless RTR (ready-to-run)	1
20110	RC18MT RTR (ready-to-run)	1
20115	RC18R Kamino RTR (ready-to-run)	1
20118	RC18R Niteline RTR (ready-to-run)	1
20120	SC18 RTR (ready-to-run)	1
20121	SC18 Brushless RTR (ready-to-run)	1
20130	RC18LM RTR (ready-to-run)	1

:: 1/12, 1/10 Kits and RTR's

2033	FT Nitro TC3 Kit	1
2042	Nitro TC3 RTR Plus (ready-to-run)	1
4019	FT 12R5.1 Kit	1
7020	RC10T4 Team Truck Kit	1
7023	RC10T4.1 FT Kit	1
7027	SC10 2WD Short Course Race Truck Kit	1
7029	SC10 Associated/RC10.com Truck RTR (ready-to-run)	1
7030	SC10 KMC Wheels Race Truck RTR (ready-to-run)	1
7032	SC10 Ready Lift RTR (ready-to-run)	1
7034	SC10 FT Kit	1

:: 1/12, 1/10 Kits and RTR's cont.

7036	RC10T4.1 RTR 2.4GHz Brushed (ready-to-run)	1
7037	RC10T4.1 RTR 2.4GHz Brushless (ready-to-run)	1
7040	SC10 RTR, 2.4ghz Brushless Lucas Oil Body	1
7041	SC10 RTR, 2.4ghz Brushless Speed Tech/Bully Dog Body	1
7043	SC10 RTR, 2.4ghz Brushless Pro Comp Body	1
7044	SC10 RTR, 2.4ghz Brushless Rockstar / MakitaBody	1
7080	FT GT2 Nitro Truck Kit	1
7092	GT2 RS Truck Nitro RTR (ready-to-run)	1
8020	FT RC10R5 Kit	1
8021	FT RC10R5-OVAL Kit	1
9034	RC10B4 Buggy Team Kit	1
9036	RC10B4.1 FT Kit	1
9038	RC10B4.1 RTR 2.4GHz Brushed (ready-to-run)	1
9039	RC10B4.1 RTR 2.4GHz Brushless (ready-to-run)	1
9060	FT B44 4WD Buggy Kit	1
20515	MGT 3.0 Nitro Monster Truck RTR (ready-to-run)	1
30105	FT TC5R Rubber Tire Edition 4WD Touring Car Kit	1
30106	FT TC6 4WD Touring Car Kit	1
30111	TC4 4WD Touring Car RTR (ready-to-run)	1

:: 1/8 Kits and RTR's

20503	Limited Edition MGT 4.60 Nitro RTR, w/flag body (ready-to-run)	1
20504	Limited Edition MGT 8.0 Nitro RTR, w/flag body (ready-to-run)	1
80902	FT RC8B Nitro Buggy Kit	1
80904	FT RC8Be Electric Buggy Kit	1
80905	RC8RS "Race Spec" Nitro Buggy RTR (ready-to-run)	1
80912	RC8T Championship Edition	1
80915	RC8T-RS "Race Spec" Nitro Truggy RTR (ready-to-run)	1
80920	SC8 Short Course Race Truck, Red Bull Nitro RTR (ready-to-run)	1
80921	SC8 Short Course Race Truck, Lucas Oil Nitro RTR (ready-to-run)	1
80922	SC8 Short Course Race Truck, KMC Wheels Nitro RTR (ready-to-run)	1
80923	SC8 Short Course Race Truck, Bully Dog Nitro RTR (ready-to-run)	1
80924	SC8 Short Course Race Truck, AE Team Nitro RTR (ready-to-run)	1
80925	SC8 Short Course Race Truck, Pro Comp Nitro RTR (ready-to-run)	1
80932	SC8e Short Course Race Truck Rockstar/Makita RTR (ready-to-run)	1

:: Tools

1111	FT Turnbuckle Wrench	1
1449	Offroad Ride Height Gauge	1
1450	FT Ride Height Gauge	1
1541	FT Hex Driver Set, (7 pcs)	1
1542	FT .050" Silver Hex Driver	1
1543	FT 1/16" Black Hex Driver	1
1544	FT 1.5mm Purple Hex Driver	1
1545	FT 5/64" Blue Hex Driver	1
1546	FT 3/32" Gold Hex Driver	1
1547	FT 2.5mm Green Hex Driver	1
1548	FT 3mm Red Hex Driver	1
1551	FT Screwdriver Set	1
1553	FT Phillips Silver Screwdriver	1
1554	FT Silver Spring Hook Tool	1
1561	FT Nut Driver Set, (6 pcs)	1
1562	FT 3/16" Black Nut Driver	1
1563	FT 1/4" Red Nut Driver	1
1564	FT 5.5mm Red Nut Driver	1
1565	FT 11/32" Green Nut Driver	1
1566	FT 7.0mm Silver Nut Driver	1
1567	FT 8mm Gold Nut Driver	1
1589	FT 5/64" Blue Ball Hex Driver	1
1590	FT 3/32" Gold Ball Hex Driver	1
1592	FT Ball Hex Driver Set, (3 pcs)	1
1719	FT Camber + Track Width Tool	1

:: Tools cont.

1737	FT Body Scissors	1
3718	12 Inch Nylon Wire Ties	12
3719	6 Inch Nylon Wire Ties	12
3720	8 Inch Nylon Wire Ties	12
3987	FT Droop Gauge	1
6429	Shock Building Tool	1
6956	Molded Tools, Set	1
7709	4 Inch Nylon Wire Ties	12

:: Contact Information

Associated Electrics, Inc.
26021 Commercentre Drive
Lake Forest, CA 92630-8853 USA
<http://www.TeamAssociated.com>
<http://www.RC10.com>
[http://twitter/Team Associated](http://twitter/TeamAssociated)
<http://bit.ly/AEonFacebook>

call: (949) 544-7500

fax: (949) 544-7501

Check out the following web sites for all of our electric kits, current products, new releases, setup help, tips, and racing info!

www.TeamAssociated.com - www.RC10.com

:: Notes

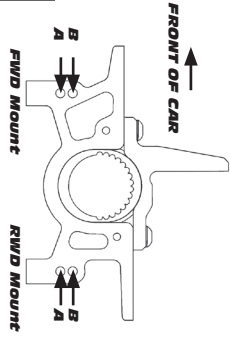
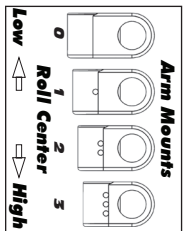
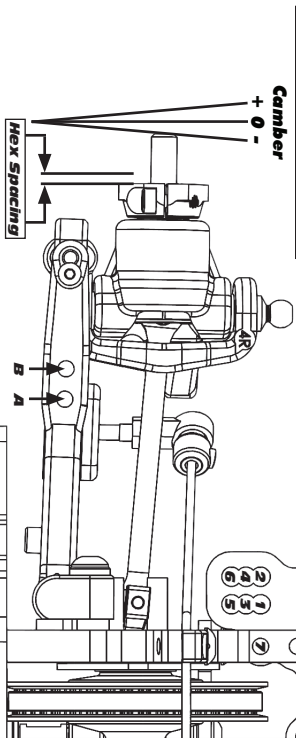
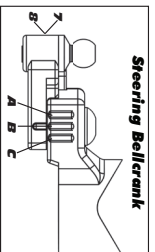
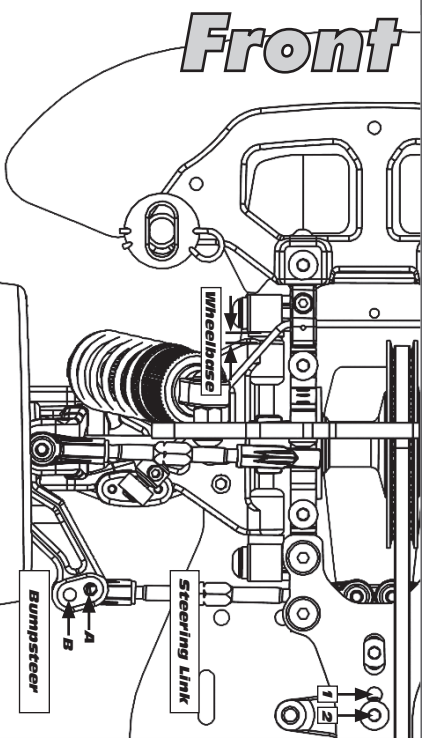

Front	Alignment	Rear
5mm	Ride Height	5mm
-1.5 deg	Camber	4.5 deg
4 deg	Caster	N/A
N/A	Rear Hub Toe	0
+ 0.5 deg	Toe (Total)	-2.5 deg
-	Hex Spacing	-
1mm	Wheelbase	1mm
7B	Steering Bellcrank	N/A
2B	Steering Link	N/A
Black + 0	Bumpsteer	N/A

Notes:

Suspension Geometry

3B	Shock Position	3B
7	Camber Link Position	7A
Silver + 0	Outer Ball & Shims	Black + 3mm
2B	FWD Arm Mount	2B
2 deg	FWD Mount Shim	1.5 deg
2B	RWD Arm Mount	2B
2 deg	RWD Mount Shims	4 deg
7	Droop	6
1.25mm	Anti-Roll Bar	1.25mm

Notes:

Shocks

40	Oil	40
3	Piston	3
50%	Rebound	50%
Silver	Spring	Green

Notes:

Differentials

Slipper Spool	Type	Alum Diff
Tight!!!	Setting	1/8 Turn Loose
A	Cam Holder	A
28	Belt Tension Number	6

Notes:

Tires

Type	Tire Diameter	Insert & Wheel	Additive & Amount

Notes:

Chassis

Classis	Top Plate

Notes:

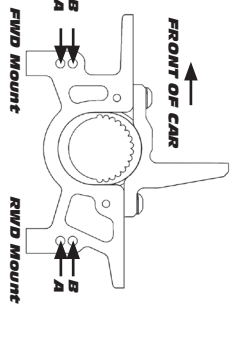
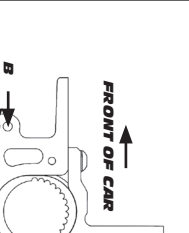
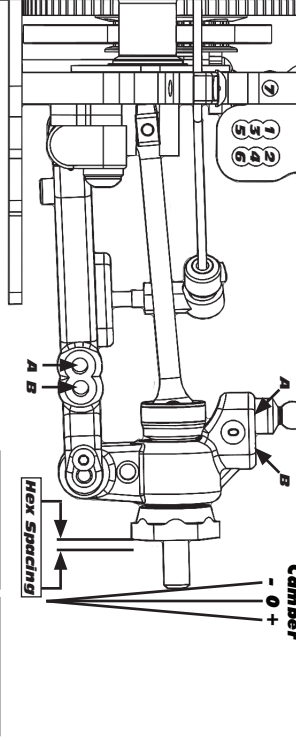
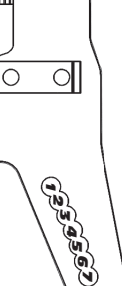
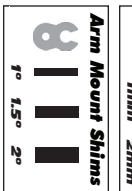
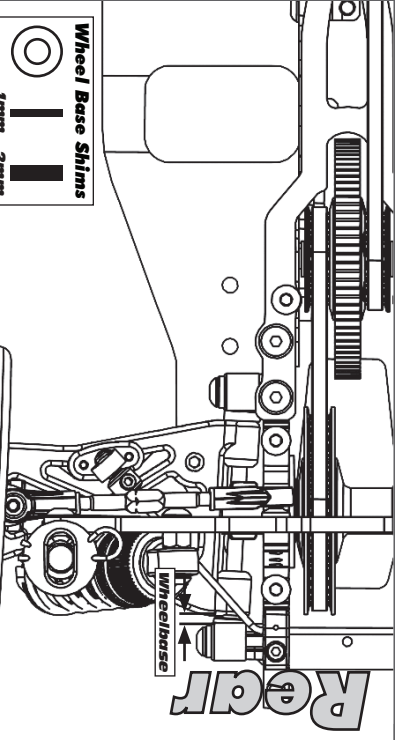

Shocks

40	Oil	40
3	Piston	3
50%	Rebound	50%
Silver	Spring	Green

Notes:

Differentials

Slipper Spool	Type	Alum Diff
Tight!!!	Setting	1/8 Turn Loose
A	Cam Holder	A
28	Belt Tension Number	6

Notes:

Tires

Type	Tire Diameter	Insert & Wheel	Additive & Amount

Notes:

Chassis

Classis	Top Plate

Notes:

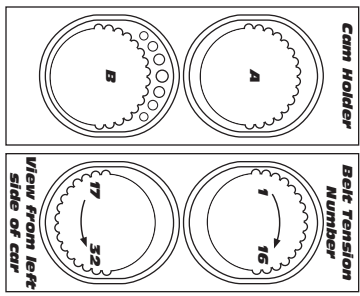

Transmitter

Turning Circle: _____

Steering Expo: _____

Brake E.P.: _____

Throttle Expo: _____

Motor

Gearing: _____

Chassis

Top Plate: _____

Speed Control

E.S.C. Type: _____

E.S.C. Settings: _____

Battery Placement

View from left side of car

Notes: _____

Notes: _____

Notes: _____

Notes: _____

Notes: _____

Notes: _____

Notes: _____

Notes: _____

For more setups, visit RC10.com and click on "Rating"

:: Hardware - 1:1 Scale View

Cap Head (shcs)



Setscrew



Ballstuds



Ball Bearings

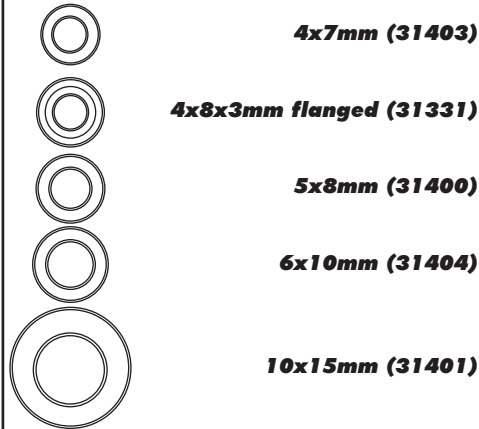

Flat Head (fhcs)

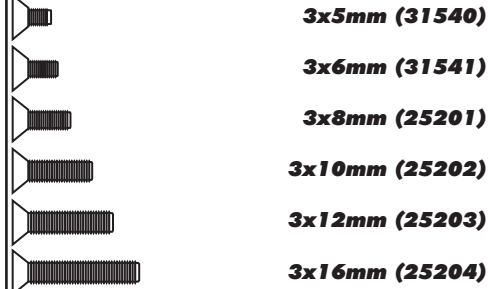

Shims and Washers



Button Head (bhcs)

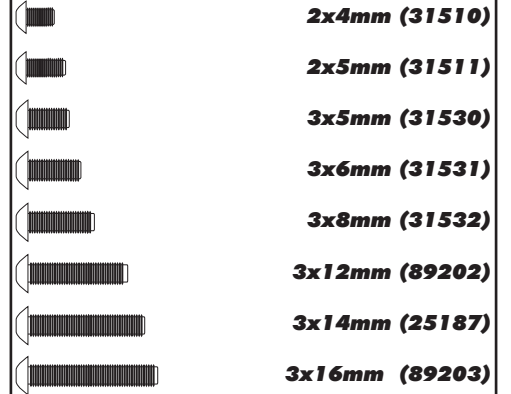

Nuts (lock/plain)

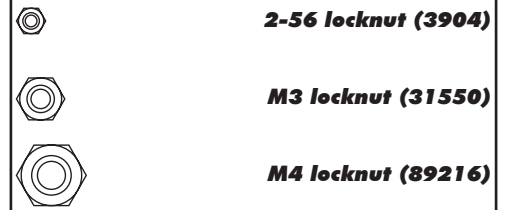

Clips



Notes:

Driver: _____
Track: _____
Conditions: _____

Date: _____
Event: _____

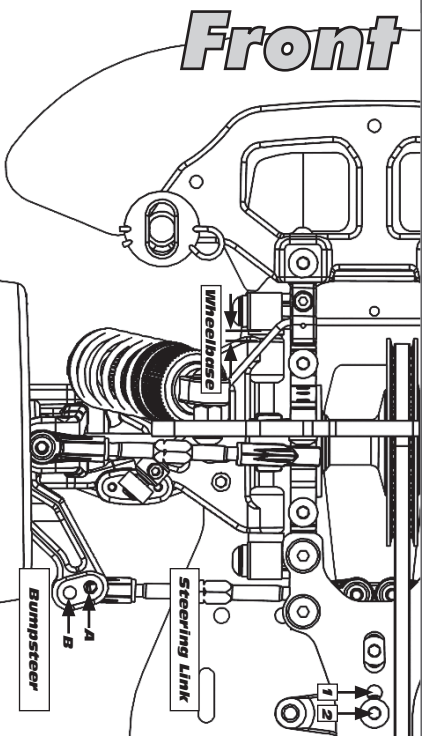

Front	Alignment	Rear
	Ride Height	
	Camber	
	Caster	N/A
N/A	Rear Hub Toe	
	Toe (Total)	
	Hex Spacing	
	Wheelbase	
	Steering Bellcrank	N/A
	Steering Link	N/A
	Bumpsteer	N/A

Notes:

Suspension Geometry

Shock Position
Camber Link Position
Outer Ball & Shims
FWD Arm Mount
FWD Mount Shim
RWD Arm Mount
RWD Mount Shims
Droop
Anti-Roll Bar

Notes:

Shocks

Oil
Piston
Rebound
Spring

Notes:

Differentials

Type
Setting
Cam Holder
Belt Tension Number

Notes:

Tires

Type
Tire Diameter
Insert & Wheel
Additive & Amount

Notes:

Chassis

Classis:
Top Plate:

Notes:

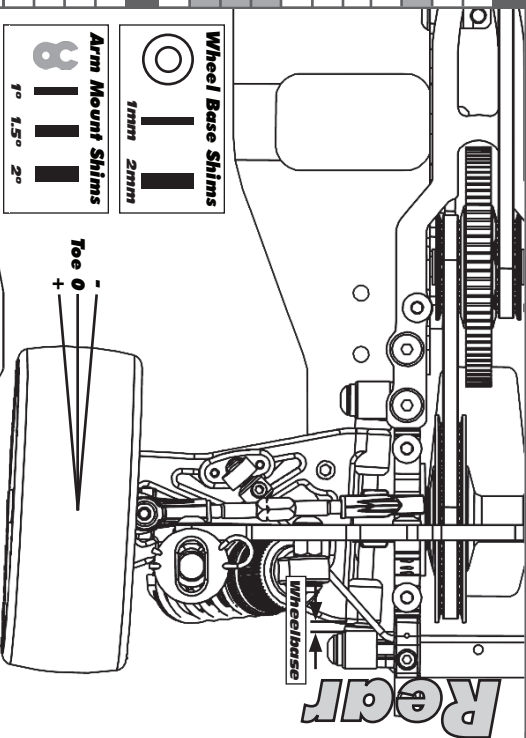

Wheel Base Shims



Arm Mount Shims

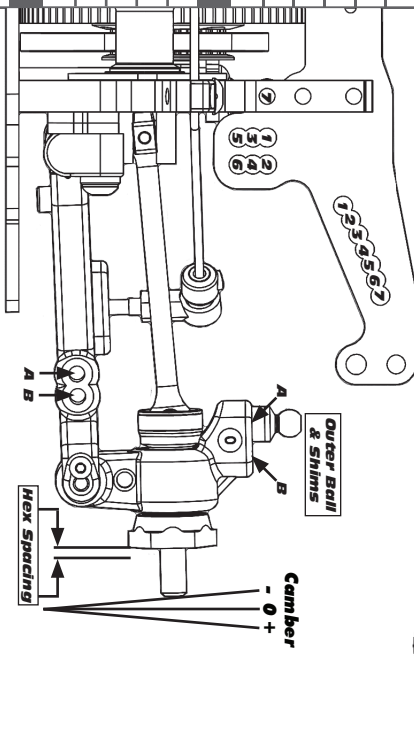

Camber

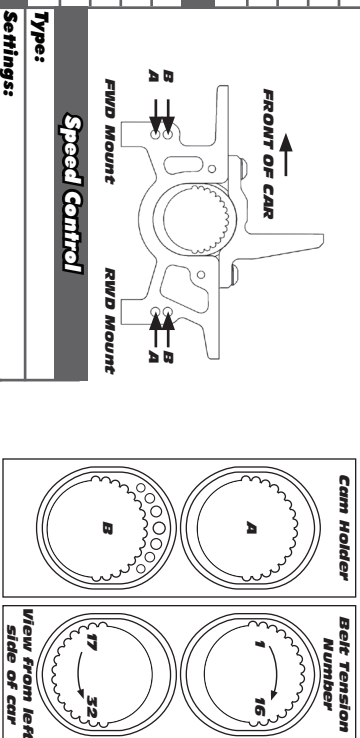

Cam Holder



Belt Tension Number



Speed Control

Type:
Settings:

Body & Wing

Notes:

Battery Placement



Front

Rear

Toe 0

Toe 0

8

1.5°

2°

Outer Ball & Shims

Outer Ball & Shims

Hex Spacing

Hex Spacing

FRONT OF CAR

FRONT OF CAR

FWD Mount

FWD Mount

RWD Mount

RWD Mount

Arm Mounts

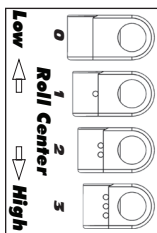

Low

High

Transmitter

Turning Circle:

Steering Expo:

Brake E.P.:

Throttle Expo:

Motor

Gearing

Notes:

Notes:

Notes:

Notes:

Notes:

For more setups, visit RC10.com and click on "Racing"



**Associated Electrics, Inc.
26021 Commercentre Dr.
Lake Forest, CA 92630 USA**

<http://www.TeamAssociated.com>

<https://www.RC10.com>

https://twitter/Team_Associated

<https://bit.ly/AEonFacebook>

call: (949) 544-7500 - fax: (949) 544-7501

**Check out the following web sites for all of our kits,
current products, new releases, setup help, tips, and racing info!
www.TeamAssociated.com - www.RC10.com**